



Taiwan Excellent Auto Engine Parts
Warranty for

2 Year / 20,000 km

VALVE GUIDE



Contact Person: Mr. Jacky Tsai
Email 1: eton.jacky@msa.hinet.net
Email 2: valveparts2866@gmail.com
Tel : (8864) 2293-6969
Fax : (8864) 2293-7070
No. 90, Wenchang 1st St., North District,
Taichung City, Taiwan. 40464

E & T SCIENCE INC.

ISO/TS 16949
QS9000



VALVE GUIDE SPECIFICATION

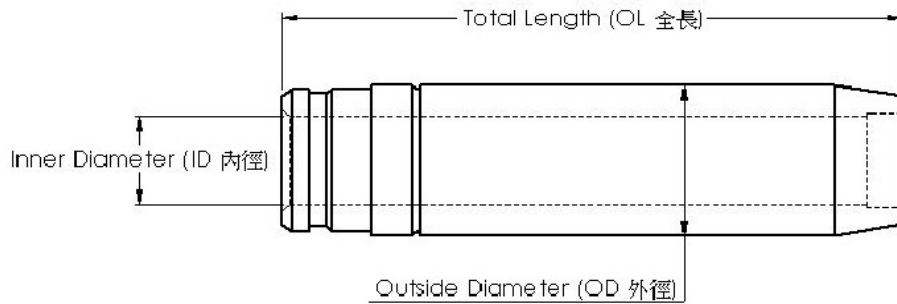

Valve Guide:

※ Cast Iron FC25

※ Hardness : **HRB 92~102°**

(mm)	Inlet valve (μm)	Exhaust valve (μm)
Stem dia. 6 - 7	10 - 40	25 - 55
Stem dia. 8 - 9	20 - 50	35 - 65
Stem dia. 10 - 12	40 - 70	55 - 85

Surface finish Ra $\leq 0.8\mu\text{m}$

Inner diameter tolerance $\leq 0.01\text{mm}$

Outer diameter tolerance $\leq 0.01\text{mm}$

Concentricity diameter tolerance

$\leq 0.05\text{mm}$ $\text{\textcircled{C}} \phi 0.05$

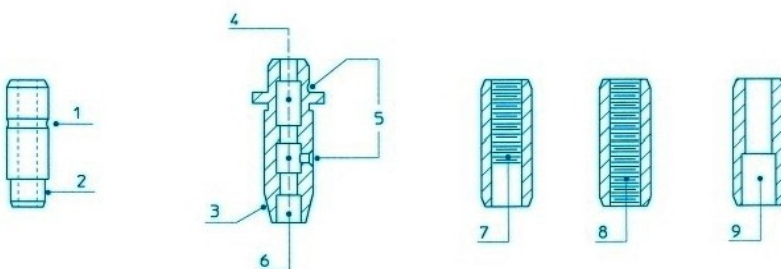
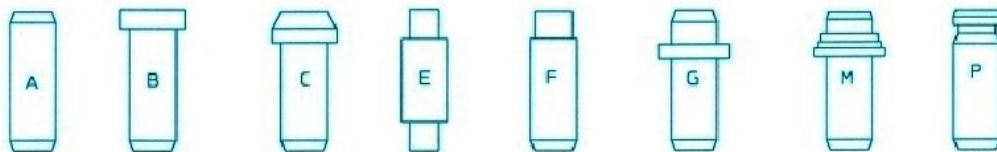

1. Outer groove for snap ring
2. Narrower end
3. Conical end
4. Recessd area in the bore
5. Lubrifation holes
6. Counterbore at end of guides
- 7/8. Lubrifation threads
9. Counter bore



日本車系

DAIHATSU(大發)	CAR;TRUCK
HINO(日野)	HEAVY DUTY;TRUCK
HONDA(本田)	CAR
ISUZU(五十鈴)	CAR;TRUCK
KOMATSU(小松)	HEAVY DUTY;TRUCK
MAZDA&FORD(馬自達 , 福特)	CAR;TRUCK
MITSUBISHI(三菱)	CAR;TRUCK;HEAVY DUTY
NISSAN(日產)	CAR;TRUCK;HEAVY DUTY
SUBARU(速霸陸)	CAR
SUZUKI(鈴木)	CAR
TOYOTA(豐田)	CAR;TRUCK
YANMAR(野馬)	MARINE;FRAME
KUBOTA(久保田)	FRAME
HYUNDAI(現代)	CAR;TRUCK
KIA(起亞)	CAR;TRUCK
DAEWOO(大宇)	CAR;TRUCK

歐美車系

AUDI-VOLKSWAGEN	奧迪-福斯	
BMW	寶馬	
CATERPILLAR		
CHRYSLER	克萊斯勒	
CUMMINS	康明斯	see KOMATSU
DETROIT-DIESEL		
FIAT-IVECO-LANCIA	飛雅特	
FORD	福特	see MAZDA
GENERAL MOTORS-CASE	通用	
MAN		
MERCEDES-BENZ	賓士	
OPEL	歐寶	
PERKINS	派肯斯	
PEUGEOT-CITROEN	標緻-雪鐵龍	
RENAULT	雷諾	
LAND ROVER	路寶	
SCANIA		
VOLVO	富豪	



DAIHATSU

Engine Type	Cyl/V	C.C./CID	OEM NO	E&T NO	I/E	OL	OD	ID	TYPE
3AU	L4		11122-15020	EVGDA-01-I	IN	43	11.55	7	P-1
2A/2AL/2ALU/2ELU	L4	1.3		EVGTO-25-I	IN	43.0	11.55	7.0	P-1
3AC/LU/U/3AL/3ALU	L4	1.5	11126-15020	EVGDA-01-E	EX	49	11.55	7	P-1
4AC/4ALC/4ALU	L4	1.6		EVGTO-25-E	EX	49.0	11.55	7.0	P-1
4EC1/T;GEMINI	L4	1.5D/49kw	8-94239-423-0	EVGDA-01-I	I/E	43	11.55	7	P-1
15D/15DT	L4	1.5D/TD	OPE	EVGIS-18-Z	I/E	42.0	11.55	7.0	P
17D/TD;X17D/T	L4	1.7D/44kw	11122-15020	EVGTO-25-I	I/E	43.0	11.55	7.0	P-1
4EE1									
AB/AB30;Mini Mk1	D700	0.5	11124-87701/2	EVGDA-02/05-Z	I/E	50	12.08	7	A-1
ED10K/ED20/EFEL		1.0	550621301						
CB;CB20/22/41/90	3/6V	993cc							
G11;G100;祥瑞1000									
SV18L,D200;DL			11122-87301/2	EVGDA-06/07-Z	I/E	66.5	14.035	9	A
3K/3KC/3KH	L4	1.2/57kw	11122-24020	EVGDA-08/09-I	IN	46	13.045	8	P-1
4K/4KC		1.3/55kw		EVGTO-05-I					
2K	L4	1.0/43kw	11126-24020	EVGDA-08/09-E	EX	50	13.045	8	P-1-6
5K		1.5/64kw		EVGTO-05-E					
1C/1CL/1CTL	L4	1.8D/48kw	11126-24020	EVGDA-08/09-E	I/E	50	13.045	8	P-1-6
2C/L		2.0D/54kw							
EJDE;KF		1.0i	11124-87203	EVGDA-11-I	IN	30.5	9.77	5.0	P
EJVE		1.0i	11128-87202	EVGDA-11-E	EX	30.5	9.77	5.0	P
2T/2TB/2TC		1588	11122-25021/20	EVGTO-11-I	IN	50.0	13.035	8.0	P-1-6
T/3T/3TC		1.4/1770		EVGDA-12~14-I					
12T/13T		1.6/1.8	11126-25021/20	EVGTO-11-E	EX	54.0	13.035	8.0	P-1
				EVGDA-12~14-E					
D700/FC/FE			4023-1631	EVGDA-18-I	IN	42.2	12.05	7	G-1
F40/12R			4023-1632	EVGDA-18-E	EX	49	12.05	7	無圖
FA /F-100		1500cc	4710-1632-01	EVGDA-19-I	IN	64	14.035	8	F-1-3
V100			4610-1632	EVGDA-19-E	EX	64	14.035	8	F-1-3
FB F-200		1900cc	4111-1631-01	EVGDA-20-I	IN	64	14.035	9	F-1-3
V200			4111-1632-01	EVGDA-20-E	EX	64	14.035	9	A-1-6
B/3B;DG/DV26		3.0/3.4D	11122-56021	EVGDA-21-Z	I/E	60.0	14.035	9	A
HD/HDC/HDE	S89,	1.6/16V	11124-87101	EVGDA-22-I	IN	55	12.08	6.6	P-1
HDEEG/HDEP	DG1.3								
HE/HEEG;HEEJ	新象16V	1.5/16V	11128-87101	EVGDA-22-E	EX	55	12.08	6.6	P-1
K3/K3VE		1.3							
EF			11128-87201-000	EVGDA-23-E	EX	52	10.08	5.5	P-1
V83			11122-87303	EVGDA-24-I	IN	65.0	14.04	9.0	A



HINO

Engine Type	Cyl/V	C.C./CID	OEM NO	E&T NO	I/E	OL	OD	ID	TYPE
ED100	6	11581	11122-1100 2-400-1907-01	EVGHI-01-I	IN	92.0	20.05	12.0	G-1
			11126-1080 2-400-1908-01	EVGHI-01-E	EX	104.0	20.05	12.0	G-1
EB100	6	9036	11121-1120 2-330-1308-12	EVGHI-02-I	IN	88.0	22.05	11.7	P-F
EB200			11125-1180 2-330-1309-11	EVGHI-02-E	EX	96.2	22.05	11.7	F-6
EB300	6	9838	11122-1030A	EVGHI-03-I	IN	88.5	22.05	12.0	P
EB400			11126-1030A	EVGHI-03-E	EX	96.0	22.05	12.0	F-6
				EVGHI-032-E	EX	92.5	22.03	12.0	P-F
EH100	6	5871	11122-1090A/1050A	EVGHI-04-I	IN	70.0	17.035	9.0	F
EC100	6	5010	11121-1160 11122-1020						
DM100	6	4313	2-382-1912-00(TOY)						
DQ100	6	4507	11126-1050A/1060A	EVGHI-04-E	EX	73.0	17.035	9.0	F-6
EG100	8	14886	11125-1150 11126-1020 2-382-1913-00(TOY)						
EH300			11122-1070 2-383-1303-00	EVGHI-05-I	IN	69.5	17.035	9.0	F-1
EH500			11126-1041 2-383-1304-00	EVGHI-05-E	EX	69.5	17.035	9.0	F-1
EH700			11122-1060 11122-1200/1	EVHI-06-Z	I/E	69.0	16.035	9.0	P
EM100;M10U			11122-1120	EVGHI-07-Z	I/E	69.0	17.03	10.0	P-6
EQ100									
EK100(OLD)			11122-1010/11	EVGHI-08-I	IN	83.5	17.04	12.0	P
EK200			11126-1010	EVGHI-08-E	EX	89.5	17.04	12.0	P-6
EL100	6	7862	11122-1080	EVGHI-09-I	IN	71.0	17.04	10.0	P
			11126-1070	EVGHI-09-E	EX	76.0	17.04	10.0	P-6
EF350/500/700			11122-1020 2-390-1924-00	EVGHI-10-I	IN	96.0	17.04	12.0	P
EF100/300			11126-1020	EVGHI-10-E	EX	96.0	17.04	12.0	P-6
EF750			11122-1040	EVGHI-11-Z	I/E	87.0	17.04	12.0	P-1-6
EF550;F17C									
EK100(NEW)			11122-1011	EVGHI-08-I	IN	83.5	17.04	12.0	P
			11122-1040	EVGHI-11-Z	EX	87.0	17.04	12.0	P-1-6
DK10			11121-1140 2-301-1301-01	EVGHI-12-I	IN	87.5	22.05	12.0	F
DK20			11125-1130 2-301-1304-01	EVGHI-12-E	EX	96.0	22.05	12.0	F-6
DS50/60			2-872-1307-00	EVGHI-13-I	IN	84.5	18.54	11.0	F
DS140			2-872-1308-00	EVGHI-13-E	EX	91.0	18.54	11.0	F-6
DS70;DS80			2874-1310-00	EVGHI-14-I	IN	82.7	18.54	10.0	F
DS90			2874-1313-00	EVGHI-14-E	EX	89.0	18.54	10.0	F-6
H06C(T)			11122-1180	EVGHI-15-Z	I/E	61.0	16.035	9.0	P-F-6
H07C;K13C	6								



HINO

Engine Type	Cyl/V	C.C./CID	OEM NO	E&T NO	I/E	OL	OD	ID	TYPE
EP100 F20C 32V	6 V8	8800 20000	11122-1130	EVGHI-16-Z	I/E	68.0	17.035	10.0	P-6
1W/WO4D/WO6D			11122-1140/1215	EVGTO-40-Z	I/E	56.0	14.035	9.0	P
J08C/J07C J05C		8.0L 5.3L	11122-1220	EVGHI-17-Z	I/E	61.5	13.05	7.0	P-6
ER100/ER200	6	11600	11122-1110	EVGHI-18-Z	I/E	82.0	17.04	12.0	P-1
PO9C(T);P08C P11C	6 6	11000 10520	11122-1190	EGIS-23-Z	I/E	80.0	14.04	8.0	P-6



HONDA

Engine Type	Cyl/V	C.C./CID	OEM NO	E&T NO	I/E	OL	OD	ID	TYPE
D12B/ZA2	L4/8V	1.2/40kw	12208-634-000	EVGHO-01-I	IN	49.0	12.075	6.6	P
EB1/2/3	L4/8V	1237cc	12208-634-920	EVGHO-02-I	常用	50.5	12.08	6.6	P
EN1/2/4		1.3				52.0	12.1	6.6	P
Civic 1200			12209-634-000	EVGHO-01/2-E	EX	57.0	12.075	6.6	P
			12209-634-670						
D15B/EC/ED/EM/EW	16V	1.5/56kw	12208-634-000	EVGHO-01-I	IN	49.0	12.075	6.6	P
			12208-634-920	EVGHO-02-I	常用	50.5	12.08	6.6	P
			12205-657-310/315	EVGHO-13-E	EX	55.0	12.075	6.6	P
D13B7;D13C		1.3/48kw	12204-PJ7-305	EVGHO-03-I	I/E	47.5	11.065	5.5	6-內銷
D14A3/4;D14E1		1.4	12204-PV0-305				11.075		6-外銷
D14Z6/Z2		1.4	5-86202-093-0						
4EE-2		1.7 CTDi							
ECA1/MF2		1.0/56kw	12204-PJ7-305	EVGHO-03-I	IN	47.5	11.065	5.5	6-內銷
D12B1;L12A1		1.2	12204-PV0-305		IN		11.075		6-外銷
L13A1/7		1.4/61kw	5-86202-093-0						
LDA1/A2;D13B1/B2	16V	1.3	FDU1256(ROV)						
D14A1/2/5/7/8	16V	1.4							
D15B1/B2/B6/B7/B8	L4/16V	1493/92							
D15Z1/3/6/8	L4/16V	1493/92							
D16A3/6/7;D16Y5/7/8	L4/16V	1590/97							
D16B2/6	16V	1.6/85kw	12205-PJ7-305	EVGHO-03/5-E	EX	54.0	11.065	5.5	6-內銷
D16W1/5;D16Y2/3/6/8	16V	1.6i	5-86202-094-0		EX		11.075		6-外銷
D16Z1/2/5/6/9;D16V1	16V	1.6i	FDU1260(ROV)						
D17A1/A2/A6/A7/8/9	L4/16V	1668/102							
F18A2/3;B/B2		1.8i/74kw							
R18A1/2	16V	1.8/103kw							
F20A/3/4/6/7/8	16V	2.0i							
F20B2/B3/B6	16V	2.0i							
F20Z1/2/3	16V	2.0i							
F22B1/B2/B6/B5/B8	L4/16V	2156/132	12204-PJ7-305	EVGHO-03-I	IN	47.5	11.065	5.5	6-內銷
F22A1/3/4/6/7/8	L4/16V	2156/134	12204-PV0-305		IN		11.075		6-外銷
F22Z2	16V	2.2i/110kw	5-86202-093-0						
F23A1/A7;Z5	L4/16V	2254/138	FDU1256(ROV)						
G25A1/A4;G24A4	L5/20V	2451/150	12205-PJ7-305	EVGHO-03/5-E	EX	54.0	11.065	5.5	6-內銷
C30A1;C32A1/A6	V6/24V	2977/3206	5-86202-094-0		EX		11.075		6-外銷
J30A1/A4;J32A1/2/3	V6/24V	2997;3210	FDU1260(ROV)						
J35A3/A5;J35A1/A4	V6/24V	3471/3474							
C35A1/2	V6/24V	3475/212							
EG/EL/EF/EP	H-BACK	1.6/59kw	12204-689-305	EVGHO-11-I	IN	50.0	12.075	7.0	6
EK1	L4/12V	1751cc			IN				
EZ/EP	H-BACK	1.6/65kw	12205-689-300/305	EVGHO-11-E	EX	55.0	12.075	7.0	6



HONDA

Engine Type	Cyl/V	C.C./CID	OEM NO	E&T NO	I/E	OL	OD	ID	TYPE
ES2/ES3/ET2/A18A1	L4/12V	1829/112	12204-PA6-300/05	EVGHO-08-I	IN	49.9	12.09	6.6	P
ES1/ET	L4/8V	1829cc	12204-PC6-305	EVGHO-10-I	IN	50.5	12.08	6.6	P
A20A1/2/3/4	L4/12V	1955/119	12204-634-920	EVGHO-09-I	IN	49.8	12.07	6.6	P
BS/BT;BS1;BS2	L4/12V	1955cc	12205-689-300/305	EVGHO-11-E	EX	55.0	12.075	7.0	6
Accord 12V									
EV2	12V	1.3			EX				
EJ1	L4/8V	1335/81	12204-PA6-300/05	EVGHO-08-I	IN	49.9	12.09	6.6	P
EM1/EW1/EW3/EW4	L4/12V	1487/91	12204-PC6-305	EVGHO-10-I	IN	50.5	12.08	6.6	P
D15A2/A3	L4/12V	1487/91	12204-634-920	EVGHO-09-I	IN	49.8	12.07	6.6	P
EV1/D13A2	L4/16V	1342/82	12205-657-310/315	EVGHO-13-E	EX	55.0	12.075	6.6	P
			12205-PEO-315		EX		12.105	外銷	
ED1/ED2/ED3	L4/12V	1487/91	12205-657-310/315	EVGHO-13-E	EX	55.0	12.075	6.6	P
EW3	L4/8V	1487/91	12205-PEO-315		EX		12.105	外銷	
EF1	L4/12V	1599/98			EX				
ES			12204-PC6-305	EVGHO-10-I	IN	50.5	12.08	6.6	P
			12205-657-305	EVGHO-12-E	EX	62.7	12.12	6.6	A
EV1/EV2			12204-PA6-300/5	EVGHO-08-I	IN	49.9	12.09	6.6	P
EW/2/3/4	L4/8V	1487/91	DBP9272	EVGRO-03-I					
EV2 216(ROVER)		85~89	DBP9273	EVGHO-13-E	EX	55.0	12.075	6.6	P
				EVGRO-03-E			12.105	外銷	
B20A1/2/3/5/7/8	L4/16V	1955/119	12204-PG6-305	EVGHO-16-I	IN	45.0	12.08	6.6	P
ZC/ZC1	16V	1.6	12205-PG6-305	EVGHO-16-E	EX	50.0	12.08	6.6	P
D16A1/A8	L4/16V	1590/97	12204-PM7-305	EVGHO-15-I	IN	45.0	12.11	6.6	6
B18A1/B1	L4/16V	1834/112							
B20A;B20A5/A9	L4/16V	1958/119							
B20B;B20B4/Z2	L4/16V	1972/121	12205-PM7-305	EVGHO-15-E	EX	50.0	12.11	6.6	6
B21A1	L4/16V	2056/125							
C27A4	V6/24V	2675/163	12204-PM7-305	EVGHO-15-I	I/E	45.0	12.11	6.6	6
B20Z1/3/9	L4/16V	2.0/108kw	12204-PM7-305	EVGHO-15-I	IN	45.0	12.11	6.6	6
			104 050 57 24		EX	40.5	13.53	7.0	F-1
C25A1/2		2.5/122kw	12204-PH7-305		IN	47.0	12.07	6.6	P
C27A1		2.7/130kw	12205-PH7-305		EX	53.0	12.07	6.6	A-3
D15B1/B2/B6	L4/16V	1493/92	12204-PR3-305	EVGHO-06-I	IN	42.0	12.075	5.5	6
B16A1/A2/A3	L4/16V	1595/97		01-2587	IN	41.7	12.1	5.53	F
B17A1				EVGHO-21-I		41.7	12.07	5.5	6
B18C1/C5	L4/16V	1678/102		140-8397		41.7	12.1	5.52	6
B18C4	L4/16V	1797/110	12205-PR3-305	EVGHO-06-E	EX	47.0	12.075	5.5	6
雅哥跑車 16V	L4/16V	1.8			EX	47.0	12.1	5.53	F
				EVGHO-21-E		47.5	12.07	5.5	6
						47.6	12.1	5.52	6
GX110/120/140/160/200			12204-ZE1-305/6	EVGHO-20-I	IN	27.0	9.63	5.5	A
GXV120/140/160			12205-ZE1-315/05	EVGHO-20-E	EX	27.0	9.66	5.5	P
H22A1/A4/A2/5	L4/16V	2156/132	12204-P13-305	EVGHO-22-I	IN	43.5	12.105	5.5	6
			12205-P13-305	EVGHO-22-E	EX	52.0	12.105	5.5	6



HONDA

Engine Type	Cyl/V	C.C./CID	OEM NO	E&T NO	I/E	OL	OD	ID	TYPE
H23A1/2/3	L4/16V	2259/138	12204-PT2-305	EVGHO-23-I	IN	39.0	12.1	6.6	6
			12205-PT2-305	EVGHO-23-E	EX	43.0	12.1	6.6	6
K20A1/2/3/4/9 K24A	16V	2.0i 2.4	12204-PNA-305	EVGHO-24-I	IN	41.5	11.1	5.53	F
			12205-PNA-305	EVGHO-24-E	EX	45.5	11.1	5.53	F
B18A1/B1	L4/16V	1834/112	12204-PR4-A01		IN	45.09	12.1	6.6	5
			12205-PR4-A01		EX	50.04	12.08	6.6	6
20T2N		2.0 Tdi	12205-P5T-G00		I/E	28.0	12.04	6.95	A
EH		0.6/23kw	12201-371-305		IN	46.0	12.08	6.5	P-1
					EX	49.0	12.09	6.5	P-1
F20C2		2.0/177kw	12010-PCX-010		IN	41.5	12.1	5.53	F-1-6
			12011-PCX-010		EX	41.5	12.1	5.53	F-1
N22A1/2		2.2 CTDi	12204-RBD-305		IN	39.0	11.1	5.53	F
			12205-RBD-305		EX	43.0	11.1	5.53	F
N360		HOGA	12204-551-305	VGHO-17-I	IN	52.78	12.1	6.55	
			12205-551/568-305	VGHO-17-E	EX	59.9	12.1	6.55	
N600		HOGA	12204-558-305	VGHO-18-I	IN	50.4	12.1	6.55	
			12205-551/568-305	VGHO-17-E	EX	59.9	12.1	6.55	
S800				VGHO-20-I	IN	43.5	11.06	6.35	
				VGHO-20-E	EX	45.5	11.06	6.35	



ISUZU

Engine Type	Cyl/V	C.C./CID	OEM NO	E&T NO	I/E	OL	OD	ID	TYPE
DH100			9-11721-120-0	EVGIS-01-Z	I/E	81.0	19.05	12.0	F-1-6-7
DA120/DA640		6.1/6.4 D	11721-100 9-11721-160-0	EVGIS-02-Z	I/E	80.0	16.035	10.0	P-1-6-7
C221		2.2 D	9-11721-123-0	EVGIS-03-I	IN	55.0	14.035	8.0	P-1-6-7
C240;C190		2.4 D/2.0D	9-11721-113-0	EVGIS-03-E	EX	53.0	14.035	8.0	A-1-2
E120/T			9-11721-212-0	EVGIS-04-Z	I/E	76.0	18.035	11.0	A-1-6-7
ISU120		2.0L/122CID			I/E				
6RA1/6RB1			1-11721-001-0	EVGIS-09-Z	I/E	76.0	18.04	11.0	P-1-6-7
4BA1/4BB1/4BC1,C2		2.8/3.6/3.3	8-94032-687	EVGIS-05-Z	I/E	60.0	14.035	9.0	A-1
6BB1/6BD1	FSR113	5.4 D	5-11721-001-0						
4BD1T/4BD2T		3.9L							
6BD1T & 6BD2T Indl.	L6	5.8L							
6BG1 86~93	L6	3.0L/182CID	1-11721-013-0						
6BF1	DIESEL	5.8/6.1							
C330;D500	DIESEL	3.3/5.0	9-11721-804-0	EVGIS-15-Z	I/E	60.0	14.035	9.0	A-1
D400			94032687						
6QA1;D920;E110			9-11721-165-0	EVGIS-06-Z	I/E	84.0	19.05	12.0	P-1-6-7
10PB1;10PC1;10PE1			1-11721-004-0/1	EVGIS-07-Z	I/E	80.0	16.035	10.0	P-1-6-8
8PA1;10PA1;12PA1									
G180Z	L4	1816cc	8-94206-762-0	EVGIS-08-I	IN	46.0	12.05	8.0	A-1
4FB1	L4 D	1819cc	9-11721-174-0		IN				
G161Z/KB20 (NEW)		1.6							
GMT111N/119A	L4	1.8L/1.9L	GMT						
4ZE1;4ZD1	L4	2559/2254	8-94206-763-0	EVGIS-08-E	EX	55.0	12.05	8.0	A-1
G200Z	L4	1949cc	9-11721-175-0		EX				
4ZB1/4ZC1(T)	L4	1.8/1994cc							
4JB1;4JB1T;4JA1;4JH1			5-11721-016-0	EVGIS-10-Z	I/E	50.0	14.03	8.0	A-1-2
C190/C223(T)/C240	80-	2.0/2.2/2.4 D	94029-347						
NKR55;4JG2/一路發									
GMT 2.2 VIN"S"(80~84)	DIESEL	134CID/2.2L	5-11721-016-0	EVGIS-10-Z	I/E	50.0	14.03	8.0	A-1-2
DC23		2.2 D	SSA						
6BA1	89-		1-11721-008-0	EVGIS-11-Z	I/E	60.0	16.04	10.0	F-6-7
6SD1									
6SA1T/TC	L6	8.4L/513	94047955						
4FB1/4FC1/4FG1		1.8/2.0 D	5-11721-015-1/0	EVGIS-12-Z	I/E	60.0	12.03	8.0	A-1
4FD1/4FA1/4FE1		2.2 D							
6HK1 TC/TCN/TCS	L6/24V	7.8L/SOHC	8-94390-780-0	EVGIS-13-Z	I/E	57.0	14.05	8.0	F-1
4HK1;4HL1	L4	5.2L							
G161 ;KB20			9-11721-109-0	EVGIS-14-I	IN	52.0	14.035	8.0	P-1
OLD				EVGIS-14-E	EX	54.5	14.035	8.0	A-1
C201PT		2.2 D	11-3374	EVGIS-16-I	IN	53.0	14.04	8.0	P
C201	L4	2.0L	9-11721-139-0						
			11-3375	EVGIS-16-E	EX	55.0	14.04	8.0	P
			9-11721-153-0						



ISUZU

Engine Type	Cyl/V	C.C./CID	OEM NO	E&T NO	I/E	OL	OD	ID	TYPE
4HE1(T)/TC;4HG1 NQR 4HF1;NPR66 6HF1 6HE1(T)/TC/TCN NPR	L4/8V L6/12V	4.8L/4.5L 7.1L/435CID	8-94396-598-0	EVGIS-17-Z	I/E	60.0	14.03	9.0	A
4EC1/T;GEMINI 15D/15DT 17D/TD;X17D/T 4EE1;4JJ1	L4 L4 L4 16v	1.5D/49kw 1.5D/TD 1.7D/44kw	8-94239-423-0 OPE 11122-15020 94840-603	EVGDA-01-I EVGIS-18-Z EVGTO-25-I	I/E I/E I/E	43 42.0 43.0	11.55 11.55 11.55	7 7.0 7.0	P-1 P P-1
4XC1(T) SOHC	L4/8V	1471cc	8-94176-717-0 8-94176-718-0	EVGIS-19-I EVGIS-19-E	IN EX	USE DGIS-18-Z 50.0	11.54	7.0	P
6WA1;6WG1;6WF1			1-11721-012-0	EVGIS-20-Z	I/E	80.0	16.035	10.0	P-1
4XC1/T	L4/8V	1471cc	8-94176-708-0	EVGIS-21-I	I/E	42.0	11.05	6.0	P
4XE1W/T DOHC 4XE1 SOHC 4XF1 DOHC	16V 12V 16V	1588cc 1588cc 1788cc	8-94362-645-1 8-94364-961-1 8-94176-708-1	EVGIS-21-I	IN	42.0	11.05	6.0	P
4XE1 SOHC	12v	1588cc	8-94424-506-1	EVGIS-21-E	EX	47.0	11.05	6.0	P
4XE1W/T DOHC 4XF1 DOHC	16v 16v	1588cc 1788cc	8-94176-709-1 8-94316-157-0	EVGIS-22-Z	EX EX	46	11.06	6.0	P
6VD1/W 6VE1 DOHC	V6 V6/24V	24V/3165cc 24V/3491cc	8-94176-709-1 8-94316-157-0	EVGIS-22-Z	I/E	46.0	11.04	6.0	P
3LD1/4LD1 4LE1			8-97318-603-0	EVGIS-24-Z	I/E	42.0	11.56	7.0	P
4LC1;4LB1			8-97231-969-0	EVGIS-25-Z	I/E	38.0	11.55	7.0	P
Y22E;X22XE;X22DTH C16SEL/XE/XEL C18XE/X18XE C25XE/X25XE X14XE X16SZR;Y16XE;Z16XE F18N2 X20DTH/DTL;Y20DTH Y22DTR;D223L Y26SE Z14XE/XEP Z20LEH/L/R/T B258I/B308I	16v 16v V6 16v 16v 16v 16V 16V V6 16v 16v V6/24V	2.2 1.6i 1.8i 2.5i 1.4i 1.6i 1.8 2.0 2.2 2.6 1.4 2.0 T 2.5	8-90502-079-0 4500633 90502642 90572642 90502181 11115-85Z00 90502079	EVGIS-26-I EVGDW-01-I	I/E I/E	45.0	10.06	6.0	F



ISUZU

Engine Type	Cyl/V	C.C./CID	OEM NO	E&T NO	I/E	OL	OD	ID	TYPE
X22SE	DOHC	2180cc	8-90502-079-0	EVGIS-26-I	IN	45.0	10.06	6.0	F
T22SED	16V	2.2	4500633						
X20SE/SED	DOHC	2.0	90502642	EVGDW-01-I	IN				
G15MF		1.5	90572642						
SUZ 2.0 ETEC II Vin Z	L4/16V	2.0	11115-85Z00						
F16D/D3	16V	1.6	90502181						
B258I	V6/24V	2498cc	90502079						
B308I/E(T)	V6/24V	2961cc	8-90502-080-0	EVGIS-26-E	EX	35.1	10.03	6.0	F
GMC 181R/B	V6/24V	3.0	90572643	EVGDW-01-E	EX	35.1	10.03	6.0	F
GMC3.2-DC24V	V6/24V	3.2	90502080						
C18SED;T18SED		1.8	11116-85Z00						
T20SED/4;M161.943	16V	2.0	90502790						
4JX1-TC	16V	3.0 D	8-97136-719-0/1	EVGIS-27-Z	I/E	35.5	11.55	7.0	A
GM VORTEC VIN 8	DOHC	2.8L/16V	ISU/GM	EVGGM-03-Z	I/E	44.0	11.07	5.97	A
ISU 2.9 VIN 9	DOHC	2.9L/16V	ISU/GM	EVGIS-28-Z					
GM VORTEC "6"	DOHC	3.5L/16V	ISU/GM						
GM VORTEC VIN "E"	DOHC	3.7L/20V/L5	ISU/GM						
GM VORTEC VIN "S"	DOHC	4.2L/24V/L6	GM/SAB						
420A VIN "Y"	DOHC	1997cc	(CHR)4667411						
N12B16A/W10B16A		1.6L/16V	BMW Mini Cooper						
NEON VIN "Y"	DOHC	1996cc	CHR						
ECLIPSE	16V	95~99	MIT						
ECC;EDV;EDZ		2.0/2.4	CHR						
JEEP POWER-TECH	DOHC	2.4L/16V	CHR						
VIN 9,B,J,X,EDZ	DOHC	2.4L/16V	CHR						
VIN 8,E,S TURBO	DOHC	2.4L/16V	CHR						



KOMATSU

Engine Type	Cyl/V	C.C./CID	OEM NO	E&T NO	I/E	OL	OD	ID	TYPE
S6D114-1(9A)(9B) SA6D114-1(9C) SAA6D114E-2A-A(9D) SA6D114E-1-GD,1AA 6C;6CT;6CTA	6	8.3L	6742-01-3240 J901187/3901187 3923564/3553870 3925863 CUMMINS	EVGKO-02-Z	I/E	72.0	16.0	9.5	A
S4D95L-W-1(1A) 4D95L-(1C) 4D95L-E-2A(1E) 4D95S-1H,1J(1G) 6D95L-1(2A) 6D95L-1AF-1(2C) S6D95L-1(2E) S4D95L-1A,1B,1G(1H) S4D95L-1K(1J) S6D95L-1MM(2G) SA6D95L-1(2J)	4 4 4 4 6 6 6 4 4 6 6	3.3L/199 3.3L/199 3.3L/199 2.7L/164 4.9L/298 4.9L/298 4.9L/298 3.3L/199 3.3L/199 4.9L/298 4.9L/298	6204-19-1310/1 6204-11-1310	EVGKO-03-Z EVGKO-07-Z	I/E I/E	51.9 51.9	12.04 12.04	8.0 8.0	A A
6D105			6130-12-1310 6136-12-1330	EVGKO-04-Z	I/E	67.8	16.035	9.0	A
4D105-3C(5A) S4D105-1&2(5D) S4D105-3(5E)			6136-19-1430	EVGKO-14-Z	I/E	68.0	16.045	9.0	同04
S4D105-5A/B(5G) 4D105-5H,5T(5C) 6D105-1(6B) S6D105-1(6D) S6D105-1(6E)(6F) S6D110-1(8A) SA6D110-1(8B)			6136-19-1430	EVGKO-14-Z	I/E	68.0	16.045	9.0	同04
4D130-1&S4D130-1(11A) S4D120		D50A	6110-13-1311 6110-13-1310	EVGKO-06-Z	I/E	83.0	18.03	11.0	M
		D50A	D50A	EVGKO-20-Z	I/E	94.0	18.04	11.0	M
4D92	4		6140-19-1310	EVGKO-08-Z	I/E	63.8	14.04	9.0	F
4D94	4		6142-19-1310 885 3051 140	EVGKO-09-Z	I/E	78.0	14.04	9.0	F
S6D140			6210-16-1340 6212-16-1440	EVGKO-12-Z	I/E	72.3	16.04	10.0	F
S6D170-1(15A) S/SA/SAA6D170E-2(15B) SA6D170-1(15C)			6162-16-1341 6162-13-1341	EVGKO-13-Z	I/E	101.0	19.05	12.0	A-7
SA6D170-1(15D) SA6D170-A-1T(15E) SAA6D170E-2A(15F) SA8V170-1(16A) SA12V170-1(17A) SA12V170E-2A(17B)			6162-16-1341 6162-13-1341	EVGKO-13-Z	I/E	101.0	19.05	12.0	A-7



KOMATSU

Engine Type	Cyl/V	C.C./CID	OEM NO	E&T NO	I/E	OL	OD	ID	TYPE
4D105-5H,5J,5T(5B) 4D105-5H,5T(5C) 6D105-1(6A) S6D105-1(6C)			6136-19-1331/30 6130-19-1310	EVGKO-15-Z	I/E	69.7	16.05	10.0	A
6D125-1(10A) S6D125-1(10C)(10D)(10E) SA6D125-1(10H)			6150-12-1341(IN) 6150-12-1351(EX) 6130-12-1351	EVGKO-18-I EVGKO-16-E EVGKO-18-E	IN EX EX	72.5 67.8 67.8	16.05 16.04 16.035	10.0 9.0 9.0	F-7 F F-7
S4D155-4(14) S6D155-4(14A) SA6D155-4(14B)	L6 L6	19.3L/1175 19.3L	6107-11-1341 6127-11-1341	EVGKO-17-Z	I/E	85.0	18.035	11	A-7
4D155 S6D155			6107-11-1341 2016-11005	EVGKO-17-ZJ EVGKO-27-Z	I/E I/E	85.0 95.0	18.04 18.04	11.0 11.0	A-7 A-7
S4D155			6127-11-1341	EVGKO-24-Z	I/E	95.2	18.035	11.0	G
S6D108-1(7A) SA6D108-1(7B) SAA6D108E-2A			6221-19-1311 6221-19-1340	EVGKO-22-Z EVGKO-21-Z	I/E I/E	58.7 59.0	14.035 14.05	9.0 9.0	F F
KT19 KT38	6cyl 12cyl	1150/18.8L 2300/38.8L	CU3018818 3021693	EVGKO-23-Z	I/E	96.5	21.49	12.65	P-7
KT19 KT38	6cyl 12cyl	1150/18.8L 2300/38.8L	3201311 3202210	EVGKO-25-Z EVGCU-04-Z	I/E	91.0	21.5	12.635	A-7
S6D140-1(12A) SA&SAA6D140E-2(12B) SA6D140-1(12C) SA12V140-1(13A) SAA12V140-1(13B) SDA12V140-1(13C) SAA12V140ZE-2(13D)	L6 V12		6212-16-1440	EVGKO-29-Z EVGKO-28-Z 特殊規格	I/E I/E	72.0 72.3	16.03 16.03	10.0 10.0	P-7 F-7
S4D102E-1(3A)(3B)(3C) S4D102E-1AB(3E) SAA4D102E-2B(3F) S6D102E-1AA(4A)(4B) SA6D102E-1AA(4C)(4D) SAA6D102E-2(4E) CUM 4BT CUM 6BT			6736-18-1310 6736-19-1310(60.5)IN 3904408 4429408 6736-19-1410(52)EX 3904409 4429409		I/E				
NH220-C1/6D130			6610-11-1311	EVGCU-02-Z	I/E	87.0	19.08	10.27	A7
N/NTA/NT855 VT12/1710 NH250	L6 V12	14.0L/855 28.0L/1710	6710-11-1311 3006456 3050369	EVGCU-03-Z	I/E	86.0	19.089	11.495	A7
LTA10 M11(ISM,QSM)	L6 L6/24V	10.0L/611 11.0L/671	3073512	EVGCU-05-Z	I/E	66.6	16.53	9.69	F-7



MAZDA

Engine Type	Cyl/V	C.C./CID	OEM NO	E&T NO	I/E	OL	OD	ID	TYPE
E1/E5/D5	L4/8V	1.1/1490cc	8173-23-090	EVGMA-01-I	I/E	50.5	14.05	8.07	A-1
F6 85~99		1.6		內銷用	I/E				
F8 71~84		1.8		EVGMA-01-E		50.5	14.06	8.08	A-1-6
F8 87~97		1.7	FORD USA	外銷OD			14.07		
MA;MA B-Serie	載卡多	1.9/2.0	FORD USA						
FE;FE18;FE58;FE60/61	L4/12V	2.0							
HEF/HE3		2.0							
UC	L4/8V	1415cc	FORD USA						
B6	L4/8V	1598cc	B6Y0-10-280	EVGMA-02-I	I/E	50.0	12.04	7.0	A-1
B6/Z/D/E/F	L4/16V	1598cc			I/E				
B68;B69;B65M	L4/16V	1598cc							
KIA B6;TC88		1.6i	B6Y0-10-290	EVGMA-02-E	I/E	50.0	12.04	7.0	A-1-6
B1/B116		1.1	B6Y1-10-281		I/E	I/E可共用，合併出EX			
B3		1.3			I/E				
JE30/39;CE30	V6/18V	2954cc	B6Y0-10-290	EVGMA-02-E	IN	50.0	12.04	7.0	A-1-6
JE06;JE07	SBI DATE		JEY1-10-290	EVGMA-21-E	EX	60.0	14.046	8.077	A-1-6
FE;FEH5;KIA FE	L4/8V	1998cc	F801-23-090	EVGMA-03-I	I/E	55.0	14.07	8.07	A-1
FE	12V	1998cc	FB01-23-200		IN	用，IN無破溝			
F2/F6	L4/8V	2184cc/1.6		EVGMA-03-E	EX	55.0	14.07	8.07	A-1-6
F8(82~97)		1.8			I/E	I/E共用出EX			
RF;RF-CX;RF-N(~95)		2.0D/TD	RF01-10-280	EVGMA-04-I	IN	40.6	14.045	8.0	A-1
RF46;RF OHC		2.0D	MRF01-10-280	EVGKI-08-I	IN				
R203/R207/R290		2.2D	11116-78E01						
KIA R2		2.2D	011-10-280						
MAZ E-Serie		2.2D	RF01-10-290	EVGMA-04-E	EX	37.7	14.045	8.0	A-1-6
			011-10-290	EVGKI-08-E					
RF;RF-CX;RF-N(95~)		2.0D/TD	RF01-10-280	EVGMA-04-I	IN	40.6	14.045	8.0	A-1
KIA RF(~98)		2.0TD	MRF01-10-280	EVGKI-08-I	IN				
SUZ RF Grand Vitara			11116-78E01	EVGSU-10-I					
			011-10-280						
			RFJ5-10-290	EVGMA-09-E	EX	46.5	14.045	8.0	A-1-6
			MRFJ5-10-290/291	EVGMA-09-E2		46.5	14.045	8.0	A-1-6
DGSU-10-E			11115-78E00	EVGKI-09-E		內銷用，差溝距其餘不變			
RF(98~)		2.0TD	MRF01-10-104		IN	41.0	14.03	8.03	P-1-3
KIA			MRFJ5-10-290/291	EVGKI-09-E	EX	46.5	14.045	8.0	A-1-6
T3000/T3500			SE01-10-104	EVGMA-05-Z	I/E	54.0	14.045	9.0	A
HA E-Serie		3.0D	SG01-10-104	EVGMA-05-Z2		54.0	14.035	9.0	P-1
SL/SLT;KIA 3600		3.5D	0K410-10-104	T3000內銷專用，款式不同，USE11122-56030					
E2700/E2500;XA			0636-10-104B	EVGMA-06-Z	I/E	53.85	12.75	8.0	A
XB E-Serie		2.7	E3TZ-6510A						
MA(or Use 8173-23-090)		1.9/2.0	0221-10-280/290	EVGMA-07-Z	I/E	50.5	14.034	8.085	F-1-6
E3/E5(80~89)		1.3/1.5	0305-10-280/290						
NA	8V	1587cc	0305-23-090						
VC;VB;H816;H817		1.8	D97Z-6510A		I/E				
HE3/HEE(or Use 8173-23-090)		2.0							



MAZDA

Engine Type	Cyl/V	C.C./CID	OEM NO	E&T NO	I/E	OL	OD	ID	TYPE
PC;TC;UC		1.0/1.3/1.4	0370-10-280(IN)	EVGMA-07-Z	I/E	50.5	14.034	8.085	F-1-6
ND1500			0552-10-105A	EVGMA-08-Z	I/E	64.0	15.035	8.077	F-1-6
UA;VA Forklift		1.5/2.0	0552-10-104		I/E				
UA B-Serie		2.0	0553/0603-23-200						
T4000;TF			TF01-10-281A	EVGMA-10-Z	I/E	47.5	14.045	9.0	P
FP;FP9A/FPY3	16V	1839cc	FSY1-10-280	EVGMA-11-Z	I/E	38.0	11.06	6.0	P-1-6
FS;FS7E/G;FS-DE(T)	L4/16V	1991cc	F32Z-6510A		I/E				
K8;K819/K838	V6/24V	1845cc							
KF1;KL	V6/24V	2.0/2497cc							
ZL-DE;ZM	16V	1.5/1.6							
F2;F2-C;F2-EGI;F2L8	12V	2.2	F2Y1-23-091	EVGMA-12-Z	I/E	53.0	12.085	7.0	A-6
AM B-Serie		2.6	F2Y1-10-280A		I/E				
G6 MPV;G60	L4/12V	2606cc	E92Z-6510A						
JK26	L4/12V	2.6	E12Z-6510A						
FORD Vin L/C	L4/12V	2184cc							
F2;F2T	8V/12V	2184cc							
B3;B3ME	8V/16V	1.3	B6Z0/B620-10-280	EVGMA-13-I	IN	48.5	11.04	6.0	P-1
B5;B5E	16V	1.5	B3Y0-10-280		IN				
B6;B6T;B6ZE	L4/16V	1597cc	E9JY-6510B						
B6/D/E/F/DC;B6 EGI		金全壘打							
KIA B5;BFD;FE	16V	1.5L							
BP22/31;BP Kat	16V	1839cc	B6Z0-10-290	EVGMA-13-E	EX	48.5	11.04	6.0	P-1-6
BP52;BP012;BP-ZE	16V	1839cc	B3Y0-10-290		EX				
DHF/DHG		1.25	E9JY-6510A						
J4C		1.3							
KJ;KJ-ZEM	V6/24V	2254cc							
WLC WLAT			B6Z0-10-290	EVGMA-13-E	I/E	48.5	11.04	6.0	P-1-6
WEC WEAT	16V	3.0L	B3Y0-10-290						
Bravo BT50;Ranger			E9JY-6510A						
FORD Vin 8 91~96	16V	1.8L	B6Z1-10-280/180	EVGMA-14-I	I/E	45.0	11.05	6.0	P-1
KIA 5BP;BPD	L4/16V	1793/1839cc	F0CZ-6510A	EVGKI-10-Z					
MAZ B6;BP	L4/16V	1597/1839							
BP;BPF1;BPT;BPZE	L4/16V	1.8L	BPY0-10-290	EVGMA-14-E	EX	46.0	11.06	6.0	P-1-6
MX-5 II 98~05	16V	1.8i T			I/E				
WL;WLT(BT-50)		2.5D/TD	WLY1-10-280(97~)	EVGMA-15-Z	I/E	46.1	12.05	7.0	P-1
B2500			WLY2-10-280(~97)		I/E				
PB;TB			0249-10-130	EVGMA-16-I	IN	50.8	12.04	7.08	P-1-1
TA			0249-10-140	EVGMA-16-E	EX	49.2	12.04	7.08	P-1-1-6
			0259-23-081						
PN			PN11-10-280	EVGMA-17-Z	I/E	46.0	12.04	7.0	A-1



MAZDA

Engine Type	Cyl/V	C.C./CID	OEM NO	E&T NO	I/E	OL	OD	ID	TYPE
MONDEO 16V ASDA/B FXDA/B/C/D;FXJA/B FYJA;L1T/V L1E/F/G/H/J/K/L/N/Q CGBA/B;CHBA/B EYDB/C/D/E/F;EYPA RDA/B;RKC RKB/F/H/K/J RKC;RQB/C MHA/B EDBA/B;EDDB/C/D/F NGA/B/C/D	16V 16V 16V 16V 16V 16V 16V 16V 16V 16V 16V	1.4 1.4 1.6 1.6i 1.8 1.8 1.8i 1.8i 1.8i 1.7 2.0 2.0i		EVGMA-18-Z	I/E	36.0	12.01	6.05	A-1
L3;L3C1;GZ L8;L813 CSDA/B;QQDA/B LF;LF17/18 LF-DE;LFF7 AODA/B;AOWA CJBA/B Z6;ZJ B4184S11	16V 16V 16V 16V 16V 16V 16V 16V	2.3 1.8 1.8 2.0 2.0 2.0 2.0 1.6/1.3 1.8	LFY1-10-281 ZJY1-10-281 VOL	EVGMA-19-Z EVGVO-05-Z	I/E I/E	39.0	11.05	5.5	A
VIN 1 DURATEC VIN 1,S,G DURATEC VIN G,L DURATEC TAURUS	V6/24V V6/24V V6/24V	3.0 3.0 2.5	F5RZ-6510A	EVGMA-20-Z	I/E	48.0	12.57	6.0	A
JE;JE3 JE94	V6 V6	3.0 3.0i	JFY1-10-290 JEY1-10-290	EVGMA-21-I EVGMA-21-E	IN EX	60.0 60.0	12.04 14.045	7.0 8.07	A-1-6 A-1-6
Z5;Z5-DE 323 V	L4/16V	1489cc	Z5Y1-10-280A	EVGMA-22-Z	I/E	44.5	11.06	5.5	P-1-6
MAZDA 800			0633-10-140	EVGMA-23-Z	I/E	49.2	11.037	6.08	A-1
E2300			0600-10-104 0600-10-105	EVGMA-24-I EVGMA-24-E	IN EX	59.2 56.6	15.035 15.035	9.07 9.07	G G
1500UB			0221-10-104 0221-10-105	EVGMA-25-I EVGMA-25-E	IN EX	60.4 60.2	15.05 15.05	9.07 9.07	F-P-1 A-1
JE27;JE48;JE74	V6/24V	2954cc	JEY2-10-280 JEY2-10-290	VGMA-35-I VGMA-35-E	IN EX	48.5 56.0	11.06 11.06	6.019 6.019	5-SR 5-SR
N9B/C/D/F Sierra;Scorpio NEK;NCA;NSE;2VSA NSF/G/H/D		2.0i 2.0 2.0i 2.0i	6172956	EVGFO-01-Z	I/E	43.5	13.57	7.05	F



MAZDA

Engine Type	Cyl/V	C.C./CID	OEM NO	E&T NO	I/E	OL	OD	ID	TYPE
F4A/B Fiesta;Escort		1.4	81SM-9510LC	EVGFO-02-Z	I/E	65.0	13.57	8.07	F
F6A/B/C/D/E/F/G		1.4							
FUC;FUA/B/C/D/G/H/J		1.4							
GMA;GPA;GLB;GLA;GLW		1.1							
JBA;JPA		1.3							
L4B;L6B Sierra		1.6i							
LHA;LNA/B		1.6T							
LJB/C/D/F;LUG/LUK/LUJ		1.6i							
LP1/2;LUA/B/C/D/H		1.6i							
LR1;LRA/B		1.6i							
R2A;RED;R2C;R6A		1.8							
Dover 110(6AA);150(6CA)		5.9D	EIADDN-6510A	EVGFO-03-Z	I/E	76.0	15.935	9.525	A
2701E;2706E		3.9D							
2711E(255);2712E(254)		4.1D							
592E		3.6D							
2703E;2708E		5.4D							
2704(360T);2724E		5.9D	EIADDN-6510A	EVGFO-03-Z	I/E	76.0	15.935	9.525	A
2713E;2709E		5.9D							
2714E(380)		6.2D							
PRZ 1000				EVGFO-04-Z		43.0	11.05	5.5	P
3E/3EE SOHC	12V	1456	11122-10040	EVGTO-32-Z	I/E	40.6	11.05	6.0	P
1E/1EL		1.0		EVGFO-06-Z		40.6	11.05	6.0	P
2E/2EE/2EL/2ELC	12V	1.3							
4EFE	16V	1.3							
5EFE DOHC	16V	1497							
FYDA,B,C,D/FYJA	16V	1.6	FORD						
HWDA,B/HXDA/SHDA	Focus II	1.6	FORD						
RHBA/PNBA	Mondeo	1.6	FORD EUR						
SIERRA 1800				EVGFO-05-I	IN	64.0	13.57	8.065	F
				EVGFO-05-E	EX	67.0	13.57	8.065	F
GAS 2N;8N;9N		2.0L	8BA6510/B	EVGFO-07-Z	I/E	55.8	26.16	8.72	36-P
GAS L-HEAD Vin B	V8/16V	3.9L							
3.152		2.5D	33261723	EVGPK-01-Z	I/E	62.0	12.74	8.0	A-6
AD4.203		3.3D	732445M1						
4.203			957E6510B						
6.305		5.0D	6361520						
4.99		1.6D	FOR:404E6510A	EVGFO-08-Z	I/E				
AFN;AVG		1.9TDi	037 103 419B	EVGAV-02-Z	I/E	36.5	12.07	7.0	G
ANU;AHU;ASZ;AUY	4/8V	1896cc	(AUDI/VW)						
1Z		1.9TDi	1037143	EVGFO-09-Z	I/E				
BPC	4/16V	1840cc							
ANU;ASZ;AUY;BTB	4/8V	1896cc	027 103 419	EVGAV-07-Z	I/E	38.1	12.06	7.0	G
			(AUDI/VW)	EVGAV-07-ZS	I/E	38.1	12.06	6.98	G
				特殊規格					
AAA	6/12V	2792cc		EVGFO-10-Z	I/E				



MITSUBISHI

Engine Type	Cyl/V	C.C./CID	OEM NO	E&T NO	I/E	OL	OD	ID	TYPE
G13B/4G13	8V/12V	1299cc	MD016441	EVGMI-01-I	IN	45.0	12.07	6.6	P
G15B/4G15	8V/12V	1468cc	MD079660	與國外資料長度不同·OL=44.0 常用車款依圖面尺寸·不做另外修正					
G11B/4G11	8V	1244cc	22114-21900						
G12B/4G12	8V	1411cc							
4G61	8V	1596cc	MD016445		EVGMI-01-E	EX	50.0	12.07	6.6
G4DJ;G4AJ	8V	1596cc	22115-21900	與國外資料長度不同·OL=49.5 常用車款依圖面尺寸·不做另外修正					
HYU Sonata	16V	2.4							
2G23	2/4V	550cc	MD079661						
4G13	12V	1299cc	MD356013	EVGMI-01-I2	IN	44.0	12.11	6.6	P
4G15 90~95	16V	1.5	MD079660		IN				
TRW&SBI與016441 IN&016445 EX相同款式 可用於EVGMI-01-I/E加大0.05			MD343941	EVGMI-01-E2	EX	49.5	12.11	6.6	P-6
4G61 T	L4/16V	1597cc	22114-33000/10	EVGMI-01-I	IN	45.0	12.07	6.6	P
6G72 T;6G73	V6/24V	2972cc/2.5	MD372791	使用EVGMI-01-I 與國外資料長度不同·OL=45.5					
G4GR DOHC	L4/16V	1596/97							
G4CN	L4/16V	1836cc	22115-33000/10	EVGMI-0-E	EX	50.0	12.07	6.6	P-6
G4BP;G4JP;G4GF	16V	2.0	MD372795	使用EVGMI-01-E 與國外資料長度不同·OL=50.5			12.11		
420A DOHC	16V	1997cc							
G6AT XG300	V6/24V	2972							
G6CU DOHC	V6/24V	3500							
4G32/B/GS/T-C	L4	1597cc	MD000461	EVGMI-02-I	IN	44.0	13.07	8.0	P
4G33	L4/8V	1.5	22114-11050		IN				
4G36/4G35	8V	1.2/1.7	22114-32901	EVGMI-02-E					
4G30/4G41	8V	1.3/1.4	MD000471		EX	48.0	13.12	8.0	P-6
G37B/4G37	L4/8V	1755cc	22115-11050		EX				
G6AT;6G72 DOHC	V6/24V	2972cc		EVGMI-02-E2					
G4CS 89~91 Sirius I	L4/8V	2351cc			EX	48.0	13.11	8.0	P-1-6
G6AT(HYU) SOHC	V6/12V	2972cc	MD185850	與EVGMI-02-E差一個油環	EX	48.0	13.11	8.0	P-1-6
6G72 SOHC	V6/12V	2972cc							
4D30		3.3	MD031886	EVGMI-03-I	IN	64.0	15.035	9.0	A
6D15		7.0	ME011244	EVGMI-03-E					
4D31/34			ME031293		EX	71.65	15.035	9.0	A-6
6D10/11;6D14;6D16			MD031888		EX	71.65	15.035	9.0	A-6
4D30;31(OLD)	OLD		ME031293	EVGMI-03-I	I/E	64.0	15.035	9.0	A
6D10/11/14/15;6D17			ME011244	EVGMI-05-I					
6DS7(70)			MD031886		I/E	64.0	15.035	9.0	A
4G51/4G53		1.8/2.4	MD020550	EVGMI-05-I	IN	47.0	13.07	8.0	P
G52B/4G52	4/12V	1995cc	MD020551		IN				
G54B/T-C/4G54	4/8V	2555cc							
G63B/4G63(T)	12V/8V	1997cc	MD020560	EVGMI-05-E	EX	52.0	13.07	8.0	P-6
G64B/4G64	8V	2351cc	MD020561	EVGMI-05-E	EX				
G62B/T	8V/12V	1795cc	22115-32901		EX				
CE26;AM1;B2600	4/12V	2555cc	MAZDA						



MITSUBISHI

Engine Type	Cyl/V	C.C./CID	OEM NO	E&T NO	I/E	OL	OD	ID	TYPE
4G92	16V	1.6	MD300702	EVGMI-06-I	I/E	45.5	11.06	6.0	P
4G93	16V	1.8	MD172527				11.12		
4G63T	16V	2.0							
4G64	~00	2351cc	MD300702	EVGMI-06-I	IN	45.5	11.06	6.0	P
4G93 Pajero	~00;4WD	1834cc	MD172527		IN				
4G63 Galant	~00	2.0							
6G74	V6/24V	3497cc	MD172530	EVGMI-06-E	EX	50.5	11.06	6.0	P-6
4G69 05~12	L4/16V	2378cc							
G4GM Beta I	16V	1795cc	HYU		EX				
G4GF Beta II	16V	1975cc	HYU						
4G64	00~	2351cc	MD364870	EVGMI-07-I	IN	45.5	11.06	6.0	P
4G93 Pajero	00~	1834cc			IN				
4G63	00~	2.0							
4G94 Pajero		1999cc	MD364740	EVGMI-07-E	EX	50.5	11.11	6.0	P-1-6
6G72	V6/24V	2972cc	MD307235		EX				
6G73	V6/24V	2497cc							
4G92;4G18	16V	1.6	MD357589	EVGMI-08-I	IN	48.0	10.61	5.51	P
4G13	16V	1.3	MD357586	EVGMI-08-E	EX	55.0	10.61	5.51	P-6
4D65/T		1.8 D/TD	MD076354	EVGMI-09-I	IN	56.0	13.12	8.0	P
4D68/T		2.0 D/TD	MD076358	EVGMI-09-E	EX	58.0	13.12	8.0	P-6
4D55/T	L4/8V	2346cc	MD050523	EVGMI-10-I	IN	71.0	13.07	8.0	P
4D56/T		2.5 D/TD	22114-42520	EVGHY-08-I	IN	71.0	13.125	8.0	P
			MD050527	EVGMI-10-E	EX	74.0	13.07	8.0	P-6
			22115-42520	EVGHY-08-E	EX	74.0	13.125	8.0	P-6
4G41;2G21;4G42			MD010461	EVGMI-11-I	IN	43.7	13.6	8.0	A
Colt 1400;TT120			MD010466	EVGMI-11-E	EX	53.8	13.6	8.0	A-6
6D20			ME051120	EVGMI-12-I	IN	83.0	20.04	12.0	F-G
6D21/6D22;6D24			31101-00601						
8DC2/4/7;8DC9	V8		ME051122	EVGMI-12-E	EX	93.5	20.04	12.0	F-G-6
8DC70			30001-10603/2						
6DC;10DC			31201-30700						
6DB1			ME051122	EVGMI-12-E	I/E	93.5	20.04	12.0	F-G-6
6D40	24V		ME120085/7	EVGMI-13-Z	I/E	95.0	15.03	10.0	A-6
8M20	8	20089	ME120085		IN	95	10	15.03	A
			ME120087	EVGMI-13-Z	EX	95	10	15.03	A-9
4M40 SOHC	L4	2835cc D	ME201051/501	EVGMI-14-I	IN	44.0	13.065	8.0	P
			ME200007	EVGMI-15-I	IN	44.0	13.06	8.0	A
			ME201054/504	EVGMI-14-E	EX	51.0	13.065	8.0	P-6
			ME200009	EVGMI-15-E	EX	51.0	13.06	8.0	A-6
4M40(TD);Pajero	90~00	2.8 TD		EVGMI-39-Z	I/E	58.0	13.09	8.0	P-6
6G74 00~07	V6/24V	3.5L	ME201051/501	EVGMI-15-I	I/E	44.0	13.06	8.0	A
Pajero III			ME200007						
4DQ;4DQ1(11)			30601-20600	EVGMI-16-Z	I/E	56.0	13.035	8.0	P
S4E Forklift	L4	2.6L	34301-02200	EVGMI-22-E	I/E	56.0	13.035	8.0	P-6
S6E Forklift	L6	3.9L	30601-25600						兩款相同，差內碳溝



MITSUBISHI

Engine Type	Cyl/V	C.C./CID	OEM NO	E&T NO	I/E	OL	OD	ID	TYPE
4DR5		專用圖	30601-25600	EVGMI-17-Z2		56.2	13.035	8.0	P-6
4DQ5 4DR5			31301-10601 30301-10600	EVGMI-17-Z	I/E	58.7	13.05	8.0	A
4DR7 4DR51			ME001179 ME001188	EVGMI-18-I EVGMI-18-E	IN EX	56.0 66.0	13.05	8.0	A A-6
S6A/A2;S6B S6A3			32501-10700 32501-00700(old)	EVGMI-19-Z EVGMI-19-Z	IN I/E	85.0 85.0	18.035	10.0	P-6 P-6
S6N/S6R2			37101-00600/10600	EVGMI-20-Z	I/E	100.0	18.035	10.0	P-6
S4S;CAT 3044 S6S;CAT 3046	L4 L6	3.3L 5.0L	32A01-01600 103-9247	EVGMI-21-Z EVGCA-06-Z	I/E	50.0	12.04	8.0	A-6
S6KT CAT 3066 CAT 3064 EX:USE S4E/S6E		6.4L 4.3L	34201-01600 ME202520 1838172 34601-10600 ME202523 1838173	EVGMI-22-I EVGCA-07-I EVGMI-22-E EVGCA-07-E	IN EX	45.0 56.0	13.035	8.0	P P-6
3G83	DOHC	657cc	MD144036/8 MD144033	EVGMI-23-I EVGMI-23-E	IN EX	49.0 52.5	10.81	5.0 5.5	P-F-6 P-F-6
新威利 4G82	16V		MD113242 MD113243	EVGMI-24-I EVGMI-24-E	IN EX	45.0 56.0	10.56	5.0	P-F-6 P-F-6
新威利 1.2	8V	共同引擎	CW722260	EVGMI-25-Z	I/E	37.0	11.06	6.0	P-F
華擎 CE12S	8V	共同引擎	CW730119	EVGMI-26-Z	I/E	36.0	11.055	6.0	A
			MM408440	EVGMI-27-Z	I/E	55.0	12.06	6.57	P-1-6
			MD488441	EVGMI-28-Z	I/E	55.0	12.06	6.1	P-6
6DS			30801-00602	EVGMI-29-Z	I/E	70.1	15.035	9.0	A
4DR51 For Domestic only			ME001188 ME001179	EVGMI-30-I EVGMI-30-E	EX IN	66.0 55.8	13.03	8.0	A A
4D55				EVGMI-31-Z	I/E	56.0	13.035	8.0	A
PAJERO				EVGMI-32-Z	I/E	66.6	13.035	8.0	A
K4E;K3E			MM408441	EVGMI-33-Z	I/E	54.5	12.07	6.6	P
		專用圖	ME074634	EVGMI-34-Z	I/E	59.0	13.035	8.0	A
NM75;SD5;M7				EVGMI-35-Z	I/E	53.0	14.06	9.0	A-1
M130/M11				EVGMI-36-Z	I/E	52.6	15.06	9.0	A
NM85;NM90;NM110				EVGMI-37-Z	I/E	55.0	15.05	9.0	A-1
4M41	Pajero	3.2	ME203044 ~00 ME204179 00~ ME203036 ~00 ME204182 00~	EVGMI-38-I EVGMI-38-E	IN EX EX	54.0 47.0	12.06 12.11 12.11	6.6	P P-6 P-3-6
6M60	6/24V	7545	ME302156 ME240032	EVGMI-40-I EVGMI-40-E	IN EX	69.0 74.5	13.09	8.0	P P-6
4D56 16V 2.5D			1010A109 1010A110/1 1011A074/5/6	EVGMI-41-I EVGMI-41-E	IN EX	48.0 45.0	11.56 11.31	6.01	P-6 P



MITSUBISHI

Engine Type	Cyl/V	C.C./CID	OEM NO	E&T NO	I/E	OL	OD	ID	TYPE
K4M;K4N			MM408444	EVGMI-42-Z	I/E	49.0	14.05	7.98	P
4M51				EVGMI-43-Z	I/E	75.0	13.035	8.0	A-6
3A91/4A90 M134.910/930	12V/16V	1.1/1.3 1.1/1.3	MCC SMART	01-S2938	I/E	34.5	10.56	5.0	F
BSY 2.0				01-2632	I/E	42.0	10.06	5.98	F
F9Q1/F9Q2 F9Q760/2/772 F9Q760/770/4 F9Q680/820/826/690 F9Q718/22/30/31/34/36/50/56/52/54/58 F9Q804/08/12		1.9 1.9DCI 1.9 DTI 1.9 DCI	M889393 NIS OPE REN 77 00 859 086	01-2585	I/E	38.3	12.06	7.0	F-1



NISSAN

Engine Type	Cyl/V	C.C./CID	OEM NO	E&T NO	I/E	OL	OD	ID	TYPE
A10/S;A12		1.0	13212-H0112/0/1	EVGNI-01-I	IN	53.2	12.04	8.0	A-1
E10 86~90		1.0	13213-H0112/0/1	EVGNI-01-E	EX	EX有內凹，IN/EX合併出IN			
A13	L4/8V	1288cc	13212-H2311/1000	EVGNI-02-I	IN	49.0	12.04	8.0	A-1
A14/S	L4/8V	1393cc	13212-H8510		IN	EX有內凹，IN/EX合併出EX			
A15/S	L4/8V	1488cc	13213-H2311	EVGNI-02-E	EX	49.0	12.04	8.0	A-1-6
D11		1.5L	13213-H1000						
A12;A12A	L4/8V	1237cc	13213-H2311/1000	EVGNI-02-E	I/E	49.0	12.04	8.0	A-1-6
E10 82~86	歐規	1.0	13212-15M01	EVGNI-03-I	IN	49.0	12.05	7.0	P
E13/S 82~91		1.3			IN		12.27	13212-15M01	
E15/E/ET/S/T	歐規	1.5	13213-01M01	EVGNI-03-E	EX	55.0	12.05	7.0	A
E16/I/S 86~91		1.6		EVGNI-03-E2	EX	55.0	12.26	7.0	F
DGNI-03-E2 樣式與歐規資料相符合							12.27	13213-01M01	
E16S	美規	1597cc	13212-01M01/11	EVGNI-04-I	IN	55.0	12.04	7.0	P
E16;E16I	美規		13212-15M01/11						
	美規		13213-01M11	EVGNI-04-E	EX	58.0	12.05	7.0	P
E15	美規	1488cc	13212-01M01/11	EVGNI-04-I	I/E	55.0	12.04	7.0	P
E15S/T			13212-15M01/11						
K21;K25 Forklift		2.1/2.5L	13212-FY500	EVGNI-05-I	I/E	45.2	11.05	7.0	P
CA16/S	Gti 16V	1.6	13212-FY500	EVGNI-05-I	IN	45.2	11.05	7.0	P
CA18/D/I/S/T;CA18ET		1.8	13212-D0110/1/2		IN		11.23		
RD28/T/Ti	L6/12V	2825cc			IN	.23	13212-D0111		
CD17/T		1688	13213-D0101	EVGNI-05-E	EX	45.2	11.05	7.0	P-6
CA20E/S/EKAT		1974cc	13213-D0110		EX		11.23		
			13213-V5513		EX	.23	13213-D0111		
CA16D	Gti 16V	1.6	13212-FY500	EVGNI-05-I	IN	45.2	11.05	7.0	P
CA18ET/I/S/T	L4/8V	1809cc	13212-D0110/1/2		IN				
CA20E/S/EKAT	L4/8V	1974cc			IN	.23	13212-D0111		
CD17/T/D/TD	L4/8V	1688cc	13213-V5514	EVGNI-05-E2	EX	48.0	11.035	7.0	P-6
CD20/T/Ti		2.0 D/TD	13213-D0111		EX				
E13(NEW)	DOKURO DATE		歐規OD:11.23 13213-V5514						
J13	Forklift	1.3	13212-30001/2	EVGNI-06-I	IN	48.5	14.325	8.72	A
J15		1.5	13211-30001		IN				
J16		1.6	13211-01W10						
J20		2.0	13213-30001/2	EVGNI-06-E	EX	55.5	14.325	8.72	A
H20	Forklift	2.0	13213-01W00/10		EX				
H30	Forklift	3.0	13212-58001	EVGNI-06-I	IN	48.5	14.325	8.72	A
			13213-58001	EVGNI-06-E	EX	55.5	14.325	8.72	A
E1		1.2	13212-30001/2	EVGNI-06-E	I/E	55.5	14.325	8.72	A
SR20DI(SPI)	16V	2.0		EVGNI-07-I	IN	43.0	10.05	6.0	P
SR20i/DE	16V	1998cc	13212-53J60		IN		10.23		
SR20DE(MPI)	16V	1998cc			IN				
Sunny IV	N14		13213-44F60	EVGNI-07-E	EX	43.0	10.05	6.0	P-6
QR25DE	16V	2.5	13213-31U60		EX		10.23		
霹靂馬2.0 931					EX				



NISSAN

Engine Type	Cyl/V	C.C./CID	OEM NO	E&T NO	I/E	OL	OD	ID	TYPE
C18DET		1.8T		EVGNI-07-I	IN	43.0	10.05	6.0	P
CA18DET	16V	1809cc	13212-53J60		IN				
SR20DE	16V Gti	2.0			IN				
SR20DEEGIKat	16V Gti	2.0		EVGNI-08-E	EX		NI-07-E/OD:11.03		
			13213-53J60						P-6
VQ30DE	V6/24V	2988cc	13212-58S60	EVGNI-09-I	IN	40.0	10.035	6	P-6
VQ35DE	V6/24V	3498cc	13213-44F60	EVGNI-07-E	EX	43.0	10.05	6.0	P-6
			13213-31U60		EX				
CA16DE	L4/16V	1597cc	13212-58S60	EVGNI-09-I	IN	40.0	10.035	6	P-6
CA18DE	L4/16V	1809cc	13213-D4260	EVGNI-07-E	EX	43.0	10.05	6.0	P-6
L13/L14		1.3/1.4	13212-21010	EVGNI-10-I	IN	59.0	12.035	8.0	A-1-1
L16/S		1595cc	13212-21011		IN		OD:12.03 13212-21010		
L18/S/T		1770cc					OD:12.23 13212-21011		
L20/A/E/P/S/B		1952cc	13213-21010	EVGNI-10-E	EX	59.0	12.035	8.0	A-1-1-6
L24/E/S	L6/12V	2393cc	13213-21011		EX		OD:12.03 13213-21010		
L26	L6/12V	2565cc					OD:12.23 13213-21011		
L28/E/T	L6/12V	2753cc	13212-U0110	VEX 可共用合併出E	I/E				
LD20/LD28		2.0/2.8							
Z20E/S		1952cc							
Z20		2.0	13212-W0510/00	EVGNI-11-I2	IN	67.5	12.24	8.0	P-1-2
Z24/Z24I		2389cc	13212-W0410	EVGNI-11-I	IN		12.04		
Z22/E	L4/8V	2187cc	12010-30/83W01						
Z16		1595	13213-W0500/10	EVGNI-11-E2	EX	67.5	12.24	8.0	P-1-2-6
Z18		1770		EVGNI-11-E			12.04		
				IN/EX 可共用合併出E	I/E				
VG30			13212-V5010/11	EVGNI-12-I	IN	58.6	11.03	7.0	P
VG30T/ET/E	V6/12V	2960cc	F3XY-6510A STD				OD:11.24 Head Must Be Reamed 0.440/0.4408		
VG33E/ER(STD)	V6/12V	3275cc	13213-V5010	EVGNI-12-E	EX	63.5	12.03	8.0	P-6
VG20	V6/12V	1998cc	F3XY-6510B STD				OD:12.24 Head Must Be Reamed 0.4793/0.4802		
GA13DS/DE	4/16V	1295	13212-53Y60	EVGNI-13-I	IN	40.0	9.54	5.5	P
GA14DS/DE	4/16V	1392			IN				
GA15DS/DE	4/16V	1498			IN				
GA16DE/DS	16V	1597cc			IN				
GA18DE		1.8			IN				
QG15DE;QG16DE	16V	1.5/1.6	13213-53Y60	EVGNI-13-E	EX	40.0	9.54	5.5	P-6
QG18DE	16V	1809cc			EX				
SR18DE/Di		1.8			EX				
GA16I;GA14S	L4/12V	1597/1392	13212-77A60	EVGNI-14-I	IN	50.0	10.23	6.0	P
與美規資料外徑大+0.2			13213-77A60	EVGNI-14-E	EX	53.0	10.835	6.6	P-6
ED30/33		3.0D	13211-Z5001/5500	EVGNI-15-Z	I/E	60.0	14.05	9.0	P-6-7
FD33;FD35;FD46	4	3298/3465	13211-Z5501						
FD6(T)	L6	5.7L	13211/2-J6500						
FE6-T			13211-J2000						



NISSAN

Engine Type	Cyl/V	C.C./CID	OEM NO	E&T NO	I/E	OL	OD	ID	TYPE
SD20/SD23	L4/8V	2.0/2.3D	13211-V1700	EVGNI-16-Z	I/E	52.12	12.05	8.0	A-2-6
SD25		2488cc	13213-1700		I/E				
SD22/SD33		2.2/3.3L							
P40 Forklift	L6	4.0	13212-C6000/1	EVGNI-17-I	IN	63.0	14.34	8.715	A
			13213-C6000/1	EVGNI-17-E	EX	67.0	14.34	8.715	A
TD23(T)	L6	2.3TD	13212-43G01	EVGNI-18-Z	I/E	47.0	12.04	8.0	A-6
TD25/T/TI		2.5TD	13212-54T00/1						
TD27/E/T		2.7 TD							
TD42/T		4.2L							
TD27TI/ETI		2.7TD	13212-7F440	EVGNI-19-Z	I/E	50.0	12.05	8.0	A-6
KA24E/DE	L4/12V	2389cc	13212-40F60	EVGNI-20-I	IN	52.5	11.035	7.0	P
SOHC	V8/32V	4494cc	13212-60U60(SBI)	EVGNI-20-I2	IN		11.235		
VH45DE			13213-40F60	EVGNI-20-ES	EX	56.0	12.03	8.0	P-6
				EVGNI-20-ES2	EX		12.23		
KA24DE	L4/16V	2389cc	13212-40F60	EVGNI-20-I	IN	52.5	11.035	7.0	P
DOHC			13212-60U60(SBI)	EVGNI-20-I2	IN		11.235		
			13213-53F60	EVGNI-20-ED	EX	39.37	11.05	7.0	P
M24CB			13212-60U60	EVGNI-35-I	IN	40.0	11.04	7.0	P
KA24DE			13213-53F60	EVGNI-35-E	EX	40.0	11.04	7.0	P-6
MA10S		1.0	13212-01B11	EVGNI-21-I	IN	50.0	11.27	7.0	P
MA12S		1.2	13213-01B11		IN				
				EVGNI-21-E	EX	53.0	11.27	7.0	P-6
YD22/DDT/DDTI		2.2	13212-AD260	EVGNI-22-I	IN	59.8	10.04	6.0	P
YD25DDTI		2.5	13213-AD260		IN		10.22		
				EVGNI-22-E	EX	44.2	10.04	6.0	P
P680;L-60			13212-58001	EVGNI-23-I	IN	72.0	15.05	8.7	A
			13213-58001	EVGNI-23-E	EX	72.0	15.05	8.7	A-6
VG30DE	V6/24V	2960cc	13212-F6560		IN	46.1	10.045	6.0	5-SR
VG30DETT	V6/24V	2960cc	13213-F6560	EVGNI-24-E	EX	49.2	10.03	6.0	P-6
VE30DE	V6/24V	2960cc		EVGNI-24-E2	EX		10.23		
ND6	6	6842	13211-95000/1	EVGNI-25-Z	I/E	72.0	15.04	10.0	A
UD4/5;UD6(681)	4PCS/cyl		13211-90005	EVGNI-26-Z	I/E	67.8	13.6	8.0	A-2-6
High Cam									
RE8/RF8;RH8			13212-95005	EVGNI-27-I	IN	72.0	15.05	10.0	A-2
NF6;NE6			13212-97009						
RF8			13211-96009	EVGNI-27-E	EX	78.0	17.045	12.0	A-2-8
PF6-T			13211-96007						
UD/RD8(old)			13211-97000	EVGNI-28-I	IN	72.0	15.05	10.0	A-7
MD6;NE6									
RD8-OLD			13211-97001/2	EVGNI-28-E	EX	78.0	17.05	12.0	A-7
RE8/PD6			13212-96002						



NISSAN

Engine Type	Cyl/V	C.C./CID	OEM NO	E&T NO	I/E	OL	OD	ID	TYPE
RD8/RD10(T) RE8/RE10			13212-97001/7	EVGNI-29-I	IN	79.0	15.05	10.0	A-7
PD6/PD6T PE6/PE6T			13212-96001 13211-96005	EVGNI-30-I EVGNI-30-I2	IN 全牙	75.0 75.0	17.05 17.045	12.0 12.0	A-2-7 A-2-8
PF6T PE6T			13212-96011 13212-96009 13211-96009 13211-96007	EVGNI-31-I EVGNI-27-E	IN EX	71.0 78.0	17.05 17.045	12.0 12.0	P-2-8 A-2-7
PD6T			13212-96002 13211-96000(IN)	缺圖 EVGNI-32-E	IN EX	72.0 85.0	17 17.035	12.0 12.0	A-7 A-2-6-7
PD6 PE6	6 6	10308 11670	13212-96001	EVGNI-30-I EVGNI-30-I2	IN 全牙	75.0 75.0	17.05 17.045	12.0 12.0	A-2-7 A-2-8
			13211-97001/2	EVGNI-28-E	EX	78.0	17.05	12.0	A-7
PD6-T PE6-T	6 6	10308 11670	13212-96002 13211-97001/2	缺圖 EVGNI-28-E	IN EX	72.0 78.0	17 17.05	12.0 12.0	A-7 A-7
PF6T PE6T PD6	6 6 6	12503 11670 10308	13212-96011 13212-96009 13211-96009 13211-96007	EVGNI-31-I EVGNI-27-E	IN EX	71.0 78.0	17.05 17.045	12.0 12.0	P-2-8 A-2-7
RF8;RF8-T RG8	V8 V8	16991 17990	13212-95005 13212-97009 13211-96009 13211-96007	EVGNI-27-I EVGNI-27-E	IN EX	72.0 78.0	15.05 17.045	10.0 12.0	A-2 A-2-8
RD8 RD10 RE8 RE10	V8 V10 V8 V10	14313 17892 15115 18894	13212-97001/7 13211-97001/2	EVGNI-29-I EVGNI-28-E	IN EX	79.0 78.0	15.05 17.05	10.0 12.0	A-7 A-7
RD8(OLD)	V8	14313	13212-97000 13211-97001/2	EVGNI-28-I EVGNI-28-E	IN EX	72.0 78.0	15.05 17.05	10.0 12.0	A-7 A-7
RD8(NEW)			13211-96006		I/E				
ND6 NE6		6842 7412	13212-97000	EVGNI-28-I	IN	72.0	15.05	10.0	A-7
TB42 Forklift	L6	4.2L	13212-03J10 13213-03J10	EVGNI-33-I EVGNI-33-E	IN EX	54.0 53.0	12.05 12.05	8.0 8.0	P P-6
HR15DE HR16DE	4/16V 4/16V	1498cc 1598cc	13212-ED060 13213-ED060	EVGNI-34-I EVGNI-34-E	IN EX	42.2 42.2	9.06 9.06	5.0 5.0	P-3 P-6
阿帝瑪2.4 12V			13212-AA040 13213-AA040	EVGNI-36-I EVGNI-36-E	IN EX	40.0 45.0	11.04 11.06	7.0 7.0	P P
J18			13212/3-24WG0	EVGNI-37-Z	I/E	49.0	12.04	8.0	A
G18/20				EVGNI-38-I EVGNI-38-E	IN EX	48.0 60.0	14.075 14.075	8.0 8.0	A-3 A
RB30				EVGNI-39-I	IN EX	58.9	11.05	7.0	A-1
H22				EVGNI-41-Z	I/E	48.0	11.09	7.0	P-6-7



NISSAN

Engine Type	Cyl/V	C.C./CID	OEM NO	E&T NO	I/E	OL	OD	ID	TYPE
SD22(套管)		USE PD6更改(專用)		EVGNI-42-Z	I/E	75.0	17.05	12.0	F-7
F4R720/2	16V	2.0	13213-00QAA 77 00 109 151	EVGNI-40-Z	I/E	40.8	11.09	5.5	A
D4F712/720/722	16V	1.2		PLATINA 1.6					
K4M752	16V	1.6							
F4R720	16V	2.0							
D4F702/4	16V	1.2							
D4F712/4/6	16V	1.2							
D4F740/764/772	16V	1.2							
F4P720/2	16V	1.8							
F4P760/770/1/3/4/5	16V	1.8							
F4R700/701	16V	2.0							
F4R712/3/4/5	16V	2.0							
F4R730/6/8	16V	2.0							
F4R740/1/4/6	16V	2.0							
F4R760/1/2/3/4/6	16V	2.0							
F4R770/1/4/6	16V	2.0							
F4R780/4/7	16V	2.0							
F4R790/1/4/5/6/7	16V	2.0							
F4R811/830	16V	2.0							
K4J700/750	16V	1.4							
K4J712/3/4;K4J730/732	16V	1.4			EVGNI-40-Z	I/E	40.8	11.09	5.5
K4J770/780	16V	1.4							
K4M700/1/4/8	16V	1.6							
K4M748/710/1/6	16V	1.6							
K4M720/4;740	16V	1.6							
K4M750/2/3	16V	1.6							
K4M760/1/4	16V	1.6							
K4M782/790	16V	1.6							
K4M800/1/4;824	16V	1.6							
K4M690	16V	1.6	77 00 109 151						
QR20DE	16V	2.0	13212-8P360	EVGNI-43-I	IN	41.8	10.03	6.0	P
	16V	1798		EVGNI-43-I2	IN		10.23		
QR25DE	16V	2.5	13213-6N260	EVGNI-43-E	EX	44.0	10.03	6.0	P-6
				EVGNI-43-E2	EX		10.23		
CG10DE/GE	16V	1.0	13212-41B60	EVGNI-44-I	IN	42.0	9.52	5.5	P
CG13DE/GE	16V	1.3			IN				
CGA3DE	16V	1.4			IN				
CR10DE	16V	1.0	13213-41B60	EVGNI-44-E	EX	44.0	9.52	5.5	P-6
CR12/CR12DE	16V	1.2							
CR14DE	16V	1.4							
MR20DE/SYLPHY	16V	2.0		EVGNI-45-E	EX	44.3	10.03	5.5	P



SUBARU

Engine Type	Cyl/V	C.C./CID	OEM NO	E&T NO	I/E	OL	OD	ID	TYPE
EK23/22;EA82			38090-2100	EVGSB-01-I	IN	53.5	12.05	7.0	P
EF10;EF12;500;550			38091-2100	EVGSB-01-E	EX	57.0	12.05	7.0	P
EA62;EA63/64/65	H4/8V	1.4/1.2/1.3	88090-4100	EVGSB-02-Z	I/E	57.4	13.056	8.0	P-1
EA71	H4/8V	1595cc							
EA81/T	H4/8V	1781cc							
EA71	H4/8V	1595cc	88090-4110	EVGSB-06-Z	I/E	61.0	13.05	8.0	A
EA81	H4/8V	1781cc							
EJ20/J/EMPI;EJ202	16V	2.0	13212-AA040	EVGSB-04-Z	I/E	52.5	11.055	6.0	P
EJ22EMPI;EJ222/3;22E	H4/16V	2212cc							
EJ25;EJ25D;EJ251/2/9	H4/16V	2458cc							
EJ18E;EJ16	H4	1781cc/1.6							
EJ205T;EJ253	H4/16V	1994/2458cc							
EJ18E/EJ18SPI		1.8	13212-AA120		IN	48.5	11.08	6.0	P-3
EJ22ENPI		2.2i	13212-AA040	EVGSB-04-Z	EX	52.5	11.055	6.0	P
EJ20G/GN;EJ205/207	H4/16V	1994cc/T	13212-AA130	EVGSB-05-I	IN	39.5	11.06	6.0	P
EJ25D;EJ255;EJ257	H4/16V	2458cc/T	13213-AA120	EVGSB-05-E	EX	47.5	11.06	6.0	P-6
EN07E	4WD	0.7	13214-KA010	EVGSB-07-Z	I/E	40.0	10.08	5.5	P-6
EN07SupercHARGE		0.7							
EJ20/EJ20J	16V	2.0	13212-AA090		IN	32.5	11.07	6.0	P
EJ25D	H4/16V	2458cc	13212-AA100		EX	40.5	11.07	6.0	P
EG33D	H6/24V	3318cc	13213-AA100			1.595	0.4365	0.2365	4-SR
EZ30		3.0	13212-AA150		IN	37.0	10.08	5.5	P
			13212-AA170		IN	34.0	10.07	5.51	P
			13213-AA140		EX	44.5	10.08	5.5	P
M13A	Justy	1.3	11115-69G00		I/E	40.0	11.1	6.0	P-6



SUZUKI

Engine Type	Cyl/V	C.C./CID	OEM NO	E&T NO	I/E	OL	OD	ID	TYPE
F5A;F8A;LJ50	6V/8V		11115-73010/30	EVGSU-01-I	IN	52.5	12.07	7.0	P
ST90;800 ;好幫手			11116-73010/30	EVGSU-01-E	EX	54.5	12.07	7.0	P-6
EF13 SUB	L3/6V	1.3 4WD	11116/5-73010/30	EVGSU-03-Z	I/E	48.0	12.09	7.0	P
G10(T);G10A/B		993cc	11115-82000-001		I/E				
F8B;ST100		0.8	11115-86500-001		I/E				
G13A/BA/BB		8V	1298cc	96062385		I/E			
G16A/KC		8V	1.6	96051575		I/E			
F10A;F10D;FA10A		1.0	91118-398(BEF)		I/E				
F10A ISU		1.0	91118398	EVGSU-03-Z	IN	48.0	12.09	7.0	P
						EVGSU-01-E	EX	54.5	12.07
H25A Grand Vitara	V6 24V	2.5L	11115-85FA0-001	EVGSU-04-Z	I/E	35.0	11.07	6.0	P
H27A/B	V6 24V	2737cc	91177123						
J18A;J20A	L4/16V	1.8GT/2.0	11115-85FA1-001						
F6A	12V		11115/6-83512	EVGSU-02-Z	I/E	34.0	10.555	5.0	P
F6A			11115-81400	EVGSU-07-Z	I/E	34.0	10.58	5.0	P
M15A/M16A	16V	1.5/1.6	11115-54G00-001	EVGSU-05-Z	I/E	40.0	10.56	5.51	P-6
J24B	L4/16V	2393cc	FIA;SUB;SUZ						
G13BB	L4/16V	1295cc	11115-60B11/10	EVGSU-06-Z	I/E	32.0	11.1	5.5	P-6
G16;G16B;G16KV	16V	1588cc	GMC 96065425						
G10 SOHC	L3/6V	993cc							
			11115-30D00	EVGSU-08-Z	I/E	28.0	10.5	4.6	F-1
G13A/B/BA	L4/16V	1.3 4WD	11115-62D00-001	EVGSU-12-Z	I/E	43.0	11.1	5.5	F-1
G13K		1298cc	GMC 9111754						
G13BB		16V	1.3	11115-86500-001					
SUZ RF Grand Vitara		2.0D/TD	11116-78E01	EVGMA-04-I	IN	40.6	14.045	8.0	A-1
KIA RF(~98)		2.0TD	MRF01-10-280	EVGSU-10-I	IN				
			11115-78E00	EVGMA-09-E	EX	46.5	14.045	8.0	A-1-6
			MRFJ5-10-290/291	EVGSU-10-E					
F6A	4WD	0.6/0.7	11115-77G00-001	EVGSU-13-Z	I/E	34.0	10.6	5.51	F
K10B;K12B	12V/16V	1.0/1.2	4709231(OPE) 93194080						
K10A	4WD	1.0	11115-73G01	EVGSU-14-Z	I/E	29.4	10.6	5.5	P-6
K12A		1.2							
M13A	16V	1.3	11115-69G00		I/E	40.0	11.1	6.0	P-6
F9Q		1.9DDiS	30852114		I/E	37.8	13.06	7.0	F
D4192T/D4192T2		1.9TD	(VOL)30882363						
F8Q706/742/710/744		1.9D/TD	77 00 107 699						
F9Q674/690/710/716/812		1.9D/DTi							
F8Q730/732									
F8Q600/606/630/662/790		1.9D	F8Q600/606						
F8Q620/624/632		1.9D							



SUZUKI

Engine Type	Cyl/V	C.C./CID	OEM NO	E&T NO	I/E	OL	OD	ID	TYPE
D19AA		1.9DDiS			I/E	43.0	14.03	8.02	F
182B9.000		1.9JTD							
839A6.000/841C000		2.4JTD							
937A2/3/7.000		1.9JTD							
939A1.000		1.9JTDM							
AR32302/37101		1.9JTD							
AR32501/34202		2.4JTD							
AR33601/67501		1.9TD							
182A7/8.000		1.9TD							
182B4/9.000		1.9JTD							
185A2.000		2.4TD							
186A6/8.000		1.9JTD							
188A2/3/7/B2.000		1.9JTD							
192A1/3.000		1.9JTD							
192A8/9.000		1.9MJT							
199A5.000		1.9MJT							
223A6/7/B2.000		1.9D							
839A5.000		2.4JTD							
939A1/937A5.000		1.9MJT							
838A3/7/8.000		2.4TDS							
841C.000		2.4JTD							
Z19DT/J/L		1.9CDTi	SAB						
9HX		1.6			I/E	34.0	9.55	5.51	A
RB414D		1.4DDiS							
TOY DV4D		1.4HDi	CIT/PEU DV4D/TD						
VOL D4164T	C30/S40	1.6 D							
DV6B		1.6HDi	CIT/PEU DV6ATED4						
G8DA/B		1.4TDCi	FOR F6JA/B						
HHJA/B		1.6TDCi	FOR HHDA/B						
Y601	16V	1.6TD	MAZ MZ_CD 1.6l						
9HZ	Cooper	1.6D	MINI						
K9K	4WD	1.5DDiS			I/E	40.5	11.07	6.0	F
K9K790/6		1.5DCi	DAC						
K9K700/2/4;722/4/8;740;750/2		1.5DCi	NIS/REN						
K9K710/2/8;764/6/8;772;780		1.5DCi	NIS/REN						
K7M7	16V	1.6	NIS/REN						
D13A 08~			46816601		I/E	43.0	10.03	6.02	F
RHZ			11115-67G00		I/E	42.5	12.06	6.0	F



TOYOTA

Engine Type	Cyl/V	C.C./CID	OEM NO	E&T NO	I/E	OL	OD	ID	TYPE
B;BU;2B		3.0/3.2 D	11122-56010/20	EVGTO-01-Z	I/E	62.0	14.035	9.0	A
F/FJ;3FE/3F	L6/12V	3878/3955	11122-61011/10	EVGTO-02-I	IN	54.05	14.035	8.0	F
2F	L6/12V	4230	11126-61011/10	EVGTO-02-E	EX	59.03	14.035	8.0	F
2F 60~69		4230	11122-60020	EVGTO-31-I	IN	70.2	14.29	8.0	無圖
F/FJ		3878	11126-60021 11126-60021U10	EVGTO-31-E	EX	63.1	14.29	8.0	無圖
13B/3B	4/8V	3431 D	11122-56030	EVGTO-03-Z	I/E	60.0	14.035	9.0	P
11B;14B	4/8V	3661							
H/2H	L6/12V	3576/3980	11122-46010	EVGTO-04-I	IN	57.0	14.035	9.0	A-2
2J;5P	L4	2.5L/2.8L	11126-46010	EVGTO-04-E	EX	60.0	14.04	9.0	A-2
2K/3K/3KC/3KH	8V	1.0	11122-24020	EVGTO-05-I	IN	46.0	13.045	8.0	P-1
K/4K/4KC/5K	8V	1.1/1.3/1.5	11126-24020	EVGTO-05-E	EX	50.0	13.045	8.0	P-1-6
1C/1CL/1CTL		1.8 D	11126-24020	EVGTO-05-E	I/E	50.0	13.045	8.0	P-1-6
2C/2CL/2CTL	8V	2.0 D							
2R	Forklift	1.5L	11122-31012/10	EVGTO-06-Z	I/E	59.8	14.035	8.0	F
5R(OLD)	Forklift	2.0	11122-44010	EVGTO-07-Z	I/E	53.0	14.035	8.5	A
5R(NEW)	Forklift	2.0	11122-44011	EVGTO-08-Z	I/E	50.0	14.035	8.5	A
8R/8RC	SOHC	1858	11122-33011	EVGTO-09-I	IN	53.18	14.035	8.0	F-2
16R	8V	1.8							
18R/18RC/18RG	SOHC	1968	11126-33011	EVGTO-09-E	EX	57.15	14.035	8.0	F-2
6R/7R		1.7/1.6							
3P/4P FORKLIFT		1.3L/1.5L	11122-23010/11 11122-23020	EVGTO-10-Z	I/E	50.1	14.04	8.0	A
12R(4R,9R);2R		1.6	11122-31020						
2T/2TB/2TC		1588	11122-25021/20	EVGTO-11-I	IN	50.0	13.035	8.0	P-1-6
T/3T/3TC		1.4/1770		EVGDA-12~14-I					
12T/13T		1.6/1.8	11126-25021/20	EVGTO-11-E	EX	54.0	13.035	8.0	P-1
				EVGDA-12~14-E					
D/2D			11122-76020	EVGTO-12-Z	I/E	75.0	15.04	10.0	F
2L/2LT/2LTE/EH		2.4 D	11122-54011/10	EVGTO-14-Z	I/E	61.0	14.035	8.5	P
L		2.2 D	11126-54011/10				14.09		
2M SOHC	L6/12V	2253cc	11122-41020	EVGTO-16-I	IN	50.0	13.035	8.0	F-1
4M/4ME SOHC	L6	2563cc	11126-41021		EX	63.75	13.069	8.027	NO PIC
5ME	L6/12V	2759cc	11122-41020	EVGTO-16-I	IN	50.0	13.035	8.0	F-1
4M/4ME SOHC	L6	2563cc	11126-45020	EVGTO-17-E	EX	59.5	13.035	8.0	F-1
5F/11Z/1Z	6cyl		11122-76004	EVGTO-19-Z	I/E	56.0	14.04	9.02	A
4AF/4AFE DOHC	16V	1587/1588	11122-15030	EVGTO-18-Z	I/E	38.5	11.06	6.0	P
7AFE DOHC	16V	1762/1788	11122-74030						
HYU G4EK II/G4ED II	16V	1495	94847881						
5EFE DOHC	16V	1497	11122-74030/15030	EVGTO-18-Z	IN	38.5	11.06	6.0	P
			11122-10040	EVGTO-32-Z	EX	40.6	11.05	6.0	P



TOYOTA

Engine Type	Cyl/V	C.C./CID	OEM NO	E&T NO	I/E	OL	OD	ID	TYPE
3SF/3SFE	4/16V	1998	11122-74030/15030	EVGTO-18-Z	IN	38.5	11.06	6.0	P
5SFE	4/16V	2164	94847881						
2JZGE;2JZGTE DOHC	24V	2997	11122-16010/20 94844753	EVGTO-21-I	EX	40.5	11.04	6.0	P-1
4AGE/C/LC 4AGZE	16V	1587	11122-16020/10	EVGTO-21-I	I/E	40.5	11.04	6.0	P-1
2VZFE;3VZFE	24V	2508/2958	94844753						
5VZFE	24V	3400							
2TZFE/2TZFZE DOHC	16V	2438	11122-16020	EVGTO-21-I	IN	40.5	11.04	6.0	P-1
2RZFE DOHC	16V	2438	GM94844753						
3RZFE DOHC	16V	2693	11126-50040/50	EVGTO-21-E	EX	48.0	11.05	6.0	P-1
1UZFE 90~97	V8/32V	3969	11126-50040/50	EVGTO-21-E	I/E	48.0	11.05	6.0	P-1
5MGE	DOHC	2759	11122-43010	EVGTO-22-Z	I/E	47.5	13.035	8.0	P-1
5MGE	DOHC	2759	11122-42010		IN	37.0	11.04	6.01	P-1
7MGE/7MGTE DOHC	24V	2954	11122-16020	EVGTO-21-I	EX	40.5	11.04	6.0	P-1
15B			11122-58010/20	EVGTO-24-I	IN	59.0	11.55	7.0	P
			11126-58010	EVGTO-24-E	EX	59.0	11.55	7.0	P-6
1AC/3AC/3A/3AU	SOHC	1452	11122-15011	EVGTO-25-I	IN	43.0	11.55	7.0	P-1
3ACU/LU/3AL/LU		1.5	11122-15020	EVGDA-01-I	IN				
4AC/4ALC/4ALU	SOHC	1587	11126-15011/20	EVGTO-25-E	EX	49.0	11.55	7.0	P-1
2A/2AL/LU/2ELU		1.3	94840605/21007426	EVGDA-01-E	EX				
4EC1/T;GEMINI	L4	1.5D/49kw	8-94239-423-0	EVGDA-01-I	I/E	43	11.55	7	P-1
15D/15DT	L4	1.5D/TD	OPE	EVGIS-18-Z	I/E	42.0	11.55	7.0	P
17D/TD;X17D/T	L4	1.7D/44kw	11122-15020	EVGTO-25-I	I/E	43.0	11.55	7.0	P-1
4EE1			多款共用，ISU圖面少油環，長度不同						
1GE/GS130			11126-15020	EVGTO-25-E	IN	49.0	11.55	7.0	P-1
			11126-70020	EVGTO-27-E	EX	53.0	11.55	7.0	P-1
H;2H			11122-68010	EVGTO-26-Z	I/E	58.0	14.035	9.0	F-2
20R/22R/22RN	SOHC	2189/2366	11122-38020/21	EVGTO-29-Z	I/E	57.5	13.05	8.0	P-1
22REC		TURBO	11122-35020						
21R/21RC/RU		2.0	11122-38010	EVGTO-29-ZM	I/E	57.0	13.04	8.0	P-1
22RE/22RTEC SOHC	8V	2366cc	11122-28021						
2CE/2CT/2CTE		2.0 D	11122-64010/1	EVGTO-30-I	IN	46.0	13.07	8.0	P
3CTE(1C/2C)		2.2 D	11126-64030/10	EVGTO-30-E	EX	50.0	13.07	8.0	P
3E/3EE SOHC	12V	1456	11122-10040	EVGTO-32-Z	I/E	40.6	11.05	6.0	P
1E/1EL		1.0							
2E/2EE/2EL/2ELC	12V	1.3							
4EFE	16V	1.3							
5EFE DOHC	16V	1497							
FYDA,B,C,D/FYJA	16V	1.6	FORD	EVGFO-06-Z		40.6	11.05	6.0	P
HWDA,B/HXDA/SHDA	Focus II	1.6	FORD						
RHBA/PNBA	Mondeo	1.6	FORD EUR						
3R/3RC		1898	11122-40010	EVGTO-33-I	IN	61.5	14.035	9.0	A
			11126-40010	EVGTO-33-E	EX	67.1	14.034	9.0	A-2



TOYOTA

Engine Type	Cyl/V	C.C./CID	OEM NO	E&T NO	I/E	OL	OD	ID	TYPE
3SGELC/3SGTE	16V	1998	11122-88320/10	EVGTO-34-Z	I/E	45.0	11.04	6.0	P-1
3VZE SOHC	V6/12V	2958	11122-65020	EVGTO-35-Z	I/E	46.0	13.095	8.0	P-1
2S/2SE/2SELC	SOHC	1995	11122-63020	EVGTO-36-I	IN	48.5	13.035	8.0	P-1
4Y/4YEC	8V	2.2	11126-63020	EVGTO-36-E	EX	52.0	13.035	8.0	P-1
3Y/3YC/3YPU/PE		1998	11122-63020	EVGTO-36-I	IN	48.5	13.035	8.0	P-1
		1998	11122-71020	EVGTO-13-I	EX	50.0	13.035	8.0	P-1
1Y/2Y/3YEC		1998	11122-71020	EVGTO-13-I	IN	50.0	13.035	8.0	P-1
4Y/4YEC	Forklift	2237	11126-71020	EVGTO-13-E	EX	52.0	13.035	8.0	P-1
1HDT		4.2 TD	11122-54020	EVGTO-39-Z	I/E	40.0	13.06	8.0	P
1HZ		4.2 TD	11123-54020						
12HT;2H		4.0 TD							
3L;5L;2L II	Hiace	2.8 /3.0D							
1W/WO4D/WO6D			11122-1140	EVGTO-40-Z	I/E	56.0	9.0	14.035	P
1KRFE		1.0	11122-21010	EVGTO-41-Z	I/E	34.5	9.74	5.01	P
3SZ/3SZVE;K3VE2/K3VET		1.5/1.3	11122-21020						
1SZFE/2SZFE	16V	1.0/1.3	0221.28						
2NZFE/1NZFE,FXE	16V	1.3/1.5	11123-21010						
1RZ;2RZ	HIACE	2.0;2.5	11122-75010	EVGTO-43-Z	I/E	45.0	13.04	8.0	P
1AZFE/FSE	L4/16V	2.0	11122-28010	EVGTO-45-I	IN	38.4	10.34	5.51	P
2AZFE/FSE	L4/16V	2362cc	11126-20020/16020	EVGTO-48-E	EX	40.5	10.35	5.5	P
2AZFE/FXE	L4/16V	2362cc	11126-20020/16020	EVGTO-48-E	I/E	40.5	10.35	5.5	P
1D/1DZ			11122-76001 11126-76004	EVGTO-46-Z	I/E	50.0	13.05	8.0	P
1FZFE	L6/24V	4477cc	11122-66020	EVGTO-47-Z	I/E	42.0	11.55	7.0	P
1ZZFE/3ZZFE	16V	1.8/1.6	11122-20020	EVGTO-48-I	I/E	34.5	10.35	5.5	P
4ZZFE	16V	1.4	11122-22030						
1MZFE(V20) 96~01	V6/24V	2995cc							
1ZRFE;2ZRFE		1.6/1.8							
1MZFE(V30) 01~05	V6/24V	2995cc	11122-20020	EVGTO-48-I	IN	34.5	10.35	5.5	P
2UZFE	V8/32V	4663cc							
1UZFE	V8/32V	3969cc	11126-20020	EVGTO-48-E	EX	40.5	10.35	5.5	P
3UZFE	V8/32V	4293cc							
1GRFE		4.0							
2ZZGE	L4/16V	1795cc	11122-88600	EVGTO-49-Z	I/E	43.0	10.55	5.5	P
3SGE	16V	1998	11122-88460	EVGTO-50-Z	I/E	42.0	11.045	6.0	P
1KDFTV;2KDFTV		3.0/2.5 D-4D	11122-30020	EVGTO-51-Z	I/E	40.6	11.09	6.0	P
1NDTV		1.4 D-4D							
MINI W17;1ND		1.4 D							
2TRFE	L4/16V	2694cc	11122-75020	EVGTO-52-Z	I/E	43.5	10.34	5.5	P
1TRFE	L4/16V	1998CC	11123-75020						
3ZR	16V	2.0	11122-75020	EVGTO-53-I	IN	43.0	10.34	5.5	P
CAMRY 2.0			11126-31030	EVGTO-53-E	EX	47.0	10.34	5.5	P



YANMAR

Engine Type	Cyl/V	C.C./CID	OEM NO	E&T NO	I/E	OL	OD	ID	TYPE
2T,3T				EVGYM-02-Z	I/E	66.0	15.07	10.0	G
6CH-DT			127616-11160	EVGYM-03-I	IN	55.0	13.03	8.0	P
CH255			127616-11170	EVGYM-03-E	EX	52.0	13.03	8.0	P-6
6HA-HT			126650-11160	EVGYM-04-I	IN	76.0	22.05	12.0	F-7
6HAL-TN			126650-11170	EVGYM-04-E	EX	76.0	22.05	12.0	F-6
6HA-DT			126634-11161	EVGYM-05-I	IN	70.0	16.05	10.02	F-1
			126634-11171	EVGYM-05-E	EX	70.0	16.05	10.02	F-1-6
6LA-DT;6LAH-UTE			148616-11170	EVGYM-06-Z	I/E	85.0	19.035	11.0	P-1
TF60/90/85				EVGYM-07-Z	I/E	35.0	12.095	7.0	A
3TN100				EVGYM-08-I	IN	50.5	13.53	9.0	P
				EVGYM-08-E	EX	51.5	13.53	9.0	P
4TNE94/98;4D94E(KOM)		JCMC	129150-11810	EVGYM-09-J	I/E	45.9	13.035	8.0	P
4D94E		常用	121400-11340	EVGYM-09-I	IN	42.0	13.04	8.0	P
4D98E		常用		EVGYM-09-E	EX	48.0	13.04	8.0	P
4TNE106 D/T	4cyl		119000-11810	EVGYM-10-Z	I/E	50.5	13.53	9.0	A-1
TS180C	非通銷	專用圖	M111030093	EVGYM-11-Z	I/E	58.0	14.0	9.0	G
ER20				EVGYM-12-Z	I/E	68.0	14.0	9.0	G
TS190				EVGYM-49-Z	I/E	58.0	14.0	9.0	A-6
TS155/180			103854-11160	EVGYM-13-Z	I/E	56.0	14.04	9.0	G
TS50/60/70/80	YSE8,YSM8,YSB8		106100-11160 105282-11160	EVGYM-39-Z	I/E	44.5	12.05	7.01	G-1
TS105/130	YSE12,YSM12,YSB12		105582-11160	EVGYM-40-Z	I/E	48.0	13.04	8.01	G-1
6CT				EVGYM-14-Z	I/E	57.0	17.22	10.0	P
4TNE98/94;4TNV98			129150-11810	EVGYM-11-E	I/E	49.0	13.035	8.0	F
4TNE84 T/D	4cyl	2QM20	120130-11860	EVGYM-11-I	IN	46.0	13.035	8.0	P
3TNE84;3LM	3cyl	3QM30	129150-11810	EVGYM-11-E	EX	49.0	13.035	8.0	F
Kom 3D84E-1/2/3FB	3cyl	易輝提供		EVGYM-11-I2	IN	49.0	13.035	8.0	A-1
Kom 4D84E-3FB	4cyl			EVGYM-11-E2	EX	46.0	13.035	8.0	A-1
S165			152623-11160	EVGYM-15-I	IN	113.0	21.03	12.03	M-1
S165L-T/ST			152623-11171	EVGYM-15-E	EX	105.0	21.03	12.03	M-1
S185-T			YA990010A 146613-11160	EVGYM-16-I	IN	130.0	24.035	14.0	M-1
M200L-UT/SN M200L-DT	541616-11170		YA990020A 146613-11170	EVGYM-16-E	EX	130.0	24.035	14.0	M-1
M220			YA1000200 147644-11150	EVGYM-17-I	IN	135.0	28.03	16.03	M
M220L-EN	147642-11170		YA1000300 147644-11180	EVGYM-17-E	EX	135.0	28.03	16.03	M
KD/KL 6KFL-HT			YA0100300 135602-11162	EVGYM-18-I	IN	94.5	22.03	14.03	M
DL20 4JDL			YA0100400 135210-11172	EVGYM-18-E	EX	98.0	22.03	14.03	M



YANMAR

Engine Type	Cyl/V	C.C./CID	OEM NO	E&T NO	I/E	OL	OD	ID	TYPE
6UAL-ST/UT			139653-11161/11850	EVGYM-19-I	IN	155.0	28.03	16.03	M
T220L-UT			139653-11150/2/3	EVGYM-19-E	EX	155.0	28.03	16.03	M
6CL			S6A3001	EVGYM-20-Z	I/E	54.0	17.03	10.0	P-6
6MAL			137600-11520/220	EVGYM-22-I	IN	158.0	30.03	18.03	M
HT/HTS			137600-11170	EVGYM-22-E	EX	158.0	30.03	18.03	M
G250-EH GL-ST/6GL-UT		6GL-HT I/E	YA110020A 138613-11160	EVGYM-23-I	IN	197.0	30.03	18.03	M
G250-EH GL-ST	6GL-UT/ET		YA110030A 138603-11172/70	EVGYM-23-E	EX	217.0	30.03	18.03	M
6GL-UT	138653-11170		YA110070A 138603-11171	EVGYM-24-E	EX	194.0	26.03	18.03	G
T240					IN				
			YA120020A	EVGYM-25-E	EX	175.0	28.03	16.03	G
DS26			YA1400200	EVGYM-26-I	IN	180.0	30.03	19.03	M
				EVGYM-26-E	EX	180.0	30.03	19.03	M
T260			YA140050A	EVGYM-27-E	EX	197.0	30.03	19.03	M
			YA140050A	EVGYM-33-E	EX	197.0	30.03	19.03	M
6N21L			YA180010A	EVGYM-28-I	IN	141.9	24.03	14.035	M
6CH-HT		JCMC EX無破溝	127610-11150	EVGYM-30-I	EX	54.0	17.03	10.0	P-6
			127610-11160	EVGYM-30-E	IN	57.0	17.03	10.0	P-6
6MAL-DT			YA070020A 137676-11180	EVGYM-31-I	IN	150.0	28.03	16.03	M
			YA070030A	EVGYM-31-E	EX	150.0	28.03	16.03	M
Z280			YA130040A 153624-11360	EVGYM-32-E	EX	188.0	28.03	21.03	M
6KH(M)-TE			126616-11170	EVGYM-34-Z	I/E	82.0	19.03	10.0	P
RAL			136600-11161	EVGYM-35-I	IN	128.0	26.2	16.0	M
CH 1-330				EVGYM-36-Z	I/E	57.7	13.54	9.0	P
LD		頂部斜度		EVGYM-41-I	IN	95.0	25.03	14.02	M-1
		鑽孔		EVGYM-42-I	IN	95.0	25.03	14.02	M-1
		鑽孔+銑溝		EVGYM-42-E	EX	95.0	25.03	14.02	M-1
6NY16L			YA9910000	EVGYM-38-I	IN	100.0	21.04	12.04	M
			YA9910100	EVGYM-38-E	EX	87.0	21.04	12.04	M
6NY16			YA9914300	EVGYM-43-I	IN	99.1	21.02	12.04	
Z280			142613-11160	EVGYM-46-I	IN	200.0	36.0	21.0	M-1
			153623-11170	EVGYM-46-E	EX	200.0	36.0	21.0	M-1
878CC;388;3TN72 2GM20(F);3GM30(F)			119620-11801	EVGYM-47-Z	I/E	35	12.025	7	A-1
3TN72				EVGYM-54-Z	I/E	35.0	12.02	7.0	



YANMAR

Engine Type	Cyl/V	C.C./CID	OEM NO	E&T NO	I/E	OL	OD	ID	TYPE
366			119260-11800 119260-11110	EVGYM-48-Z	I/E	30	10.025	5.5	A
3TNE68				EVGYM-56-Z	I/E	30.2	10.05	5.5	F
TF160					I/E	45.0	14.0	9.0	
235/353				EVGYM-50-Z	I/E	40.0	12.025	7.0	A-1
6GH			123220-11171	EVGYM-51-Z	EX	51.5	13.535	9.0	A-1
HA300			126634-11161	EVGYM-52-I	IN	70.0	16.04	10.0	F-1
				EVGYM-52-E	EX	70.0	16.04	10.0	F-1-6
3TN75				EVGYM-55-I	IN	40.0	11.045	7.0	P-G-6
				EVGYM-55-E	EX	40.0	11.045	7.0	
N22Y			103202-11180		I/E	95.0	25.035	14.0	



KUBOTA

Engine Type	Cyl/V	C.C./CID	OEM NO	E&T NO	I/E	OL	OD	ID	TYPE
有唇 725;L1500				EVGKU-02-Z	I/E	47.5	13.06	8.0	G
L1500	鳴輪			EVGKU-02-Z2	I/E	47.5	13.04	8.0	G
有唇 鐵牛725				EVGKU-03-Z	I/E	48.0	13.05	8.0	G
農機725				EVGKU-04-I	IN	48.0	13.05	8.0	F
無唇				EVGKU-04-E	EX	48.0	13.04	8.0	F
久保田				EVGKU-05-I	IN	33.0	10.55	6.0	P
643G				EVGKU-05-E	EX	33.0	10.55	6.0	P-6
V2203.-B				EVGKU-06-I	IN	40.0	13.06	8.0	P-1
(MIT 3G72)				EVGKU-06-E	EX	47.0	13.06	8.0	P-1-6
GA70(KUBOTA)			常風	EVGKU-07-Z	I/E	44.0	13.055	7.0	A-1



DAEWOO

Engine Type	Cyl/V	C.C./CID	OEM NO	E&T NO	I/E	OL	OD	ID	TYPE
Y22E;X22XE		2.2	8-90502-079-0	EVGIS-26-I	I/E	45.0	10.03	6.0	F
C16SEL/XE/XEL	16v	1.6i	4500633	EVGDW-01-I	I/E				
C18XE/X18XE	16v	1.8i	90502642						
C25XE/X25XE	V6	2.5i	90572642						
X14XE	16v	1.4i	90502181						
X16SZR;Y16XE;Z16XE	16v	1.6i							
F18N2		1.8	90502079						
X20DTH/DTL;Y20DTH	16V	2.0	OPEL						
Y22DTR	16V	2.2	ISU						
Y26SE	V6	2.6							
Z14XE/XEP	16v	1.4							
Z20LEH/L/R/T	16v	2.0 T							
B258I	V6/24V	2.5	SAAB 4770269						
B308I	V6/24V	3.0							
D223L;X22DTH		2.2 TD							
X22SE	16v	2180cc	8-90502-079-0	EVGIS-26-I	IN	45.0	10.03	6.0	F
T22SED	16V	2.2		EVGDW-01-I	IN				
X20SE/SED	16V	2.0	90572642						
G15MF		1.5							
F16D/D3	16V	1.6							
B258I	V6/24V	2498cc			IN				
B308I/E(T)	V6/24V	2961cc	8-90502-080-0	EVGIS-26-E	EX	35.1	10.03	6.0	F
GMC 181R/B	V6/24V	3.0	90572643	EVGDW-01-E	EX	35.1	10.03	6.0	F
GMC3.2-DC24V	V6/24V	3.2	90502080						
C18SED;T18SED		1.8							
T20SED/4;M161.943	16V	2.0	90502790						
B10S/S1		1.0	11115A-70B00	EVGDW-02-Z	I/E	43.0	11.1	5.5	P
B12S1		1.2	94580080	EVGGM-05-Z					
F10NS CHEVROLET		1.6							
F8C/CV Matiz;Tico		0.8							
F14D3/S3	16V	1.4	96103034	EVGDW-03-Z	I/E	40.0	11.06	6.0	A
A15MF/SMS	16V	1.5	96336671	EVGGM-04-Z					
A16DMS;F16D3;616L	16V	1588/1598	GMC						
L91 E-TEC II	16V	1.6L							
M104.992/5;M111.970	V6	3.2	606 053 02 30	EVGMB-10-Z	I/E	37.5	12.56	7.0	F
M161.973		2.3	111 053 10 29	EVGDW-04-Z					



DAEWOO

Engine Type	Cyl/V	C.C./CID	OEM NO	E&T NO	I/E	OL	OD	ID	TYPE
10S	L4/8V	993cc	OPEL	EVGOP-02-Z	I/E	46.0	11.05	7.03	A-1
11N,11S/SR	L4/8V	1078cc		EVGDW-05-Z					
12N/NC/NV/NZ;12S/ST	L4/8V	1196cc							
12C;C12NZ;X12SE									
13N/NB;13S/SB;C13N	L4/8V	1297cc							
14NV;C14S/SE/SEL/NE	L4/8V	1389cc							
X14SE;X14NE/C/SZ									
16SV/NZR;E16NE/SE	L4/8V	1598cc							
C16NE/NZ2/LE;16LZ2									
C16SE/SEI;X16SE/SZR									
18E/SE/SEH;18SV/NV	L4/8V	1796cc							
C18NE/NZ/NV/NT									
E18NV/NVR									
20SE/SEH/NEJ/NE	L4/8V	1998cc							
C20NE/NEF/NEJ;X20SE									
1.3N/S;16SV			BEDFORD						
A18DMS;C18LE		1.8	DAEWOO						
A13DTC/DTE/DTR	L4/16V	1248cc							



HYUNDAI

Engine Type	Cyl/V	C.C./CID	OEM NO	E&T NO	I/E	OL	OD	ID	TYPE		
G13B/4G13	8V/12V	1299cc	MD016441	EVGMI-01-I	IN	45.0	12.07	6.6	P		
G15B/4G15	8V/12V	1468cc	MD079660	與國外資料長度不同·OL=44.0							
G11B/4G11	8V	1244cc	22114-21900	常用車款依圖面尺寸·不做另外修正							
G12B/4G12	8V	1411cc									
4G61	8V	1596cc	MD016445	EVGMI-01-E	EX	50.0	12.07	6.6	P		
G4DJ;G4AJ	8V	1596cc	22115-21900	與國外資料長度不同·OL=49.5							
HYU Sonata	16V	2.4		常用車款依圖面尺寸·不做另外修正							
2G23	2/4V	550cc	MD079661								
4G61 T	L4/16V DOHC	1597cc	22114-33000/10	EVGMI-01-I	IN	45.0	12.07 12.11	6.6	P		
4G63 T;4G63-7		1997cc	22114-33901/10								
4G64		2351cc	MD126605								
4G67		1.8	MD324101								
6G72 T;6G73	V6/24V	2972cc/2.5	MD372791	使用EVGMI-01-I							
6G74		3497cc		與國外資料長度不同·OL=45.5							
G4GR DOHC	L4/16V	1596/97									
G4CN	L4/16V DOHC	1836cc	22115-33000/10	EVGMI-0-E	EX	50.0	12.07	6.6	P-6		
G4CP		1997cc	22115-33901/10								
G4JS	16V	2351cc	MD126608				12.11				
G4BP		2.0	MD372795								
G4JP;G4GF	16V	1596cc		使用EVGMI-01-E							
G4CR					與國外資料長度不同·OL=50.5						
G6AT XG300	V6/24V	2972/181									
G6CU DOHC	V6/24V	3500/214									
4G32/B/GS/T-C	L4	1597cc	MD000461	EVGMI-02-I	IN	44.0	13.07	8.0	P		
4G33	L4/8V	1.5	22114-11050		IN						
4G36/4G35	8V	1.2/1.7	22114-32901		IN						
4G30/4G41	8V	1.3/1.4	MD000471	EVGMI-02-E	EX	48.0	13.12	8.0	P-6		
G37B/4G37	L4/8V	1755cc	22115-11050		EX						
G6AT;6G72 DOHC	V6/24V	2972cc			EX						
G4CS 89~91 Sirius I	L4/8V	2351cc									
G6AT(HYU) SOHC	V6/12V	2972cc	MD185850	EVGMI-02-E2	EX	48.0	13.11	8.0	P-1-6		
6G72 SOHC	V6/12V	2972cc		與DGMI-02-E差一個油環							
G4CS 93~00	4WD	2.4/84kw	22114-32911	EVGHY-01-I	IN	47.0	13.11	8.0	P		
H100;H-1			22115-32911	EVGHY-01-E	EX	52.0	13.11	8.0	P-6		
D4BF;D4BH		2.5 TD	22114-42000		IN	71.0	13.07	8.0	P		
D4BB;D4BX;D4BA		2.5 D	22114-42900	EVGHY-02-I	IN	71.2	13.125	8.0	P		
KIA D4BH Pregio(TB)		2.5 D	22115-42000		EX	74.0	13.07	8.0	P-6		
			22115-42900	EVGHY-02-E	EX	74.18	13.125	8.0	P-6		
4D55/T	L4/8V	2346cc	MD050523	EVGMI-10-I	IN	71.0	13.07	8.0	P		
4D56/T		2.5 D/TD	22114-42520	EVGHY-08-I	IN	71.0	13.125	8.0	P		
			MD050527	EVGMI-10-E	EX	74.0	13.07	8.0	P-6		
			22115-42520	EVGHY-08-E	EX	74.0	13.125	8.0	P-6		
G4EK	L4/12V	1495cc	22114-22900/5	EVGHY-03-I	IN	42.7	11.115	6.0	P		
G4EH/G4N	12V	1.3i	22115-22900/5	EVGHY-03-E	EX	39.0	11.1	6.0	P		



HYUNDAI

Engine Type	Cyl/V	C.C./CID	OEM NO	E&T NO	I/E	OL	OD	ID	TYPE
G4EK ALPHA I	L4/12V	1495cc	22114-22900/5	EVGHY-03-E	IN	39.0	11.1	6.0	P
G6BA DELTA 01~09	V6/24V	2656cc	22114-23000						
KIA G6BA 美規資料			22115-22900/5 22115-23901/37100	EVGHY-03-I	EX	42.7	11.115	6.0	P
G6EA;G6BA;G6BA-G	V6	2.7	22114-23000		IN	39.0	11.05	6.0	P
G6BV	V6/4WD	2.5	22115-37100		EX	43.0	11.10	6.0	P-6
G4EA 00~06		1.3	22114-22020	EVGHY-09-I	IN	Y-03-I;OD=11.06			
G4EB 00~06		1.5	22115-22020	EVGHY-09-E	EX	39.0	11.06	6.0	P
G4GC;G4GC-EG	16V	2.0L	22114-23901	EVGHY-05-I	IN	39.0	11.075	6.0	P
G4GR;G4DR	16V	1.6							
G4GM	16V	1.8	22115-23901	EVGHY-05-E	EX	44.0	11.075	6.0	P-6
G4GF;G4GF-EG	16V	2.0L							
G4CR	16V	1.6ie/78kw			IN	39.0	11.05	6.01	P
					EX	44.5	11.05	6.01	P-6
G4HD;G4HG	12V	1.1	22114-02500	EVGHY-06-I	IN	47.0	10.05	5.5	P
G4HC;G4HC-E		1.0i							
G4EA 98~;G4LA		1.3/1.2	22115-02500	EVGHY-06-E	EX	48.0	10.05	5.5	P-6
Engine Type	Cyl/V	C.C./CID	OEM NO	E&T NO	I/E	OL	OD	ID	TYPE
	12V	3.8		EVGHY-07-I	IN	82.9	15.05	9.01	A
				EVGHY-07-E	EX	82.9	15.05	8.99	A
G4ED;G4ED-G;G4GD	16V	1.6	22114-26000	EVGHY-10-I	IN	36.6	11.075	6.0	F
G4EE;G4FA 10~	16V	1.4							
G4EC-G 00~06		1.5	22115-26000	EVGHY-10-E	EX	41.0	11.075	6.0	P-6
G4GA ;Accent IV 10~		1.6							
			22114-02900	EVGHY-11-I	IN	44.0	10.1	5.5	P
			22115-02900	EVGHY-11-E	EX	48.0	10.1	5.5	P-6
D4EB	CRDi	2.2	22114-27000	EVGHY-12-Z	I/E	36.6	11.05	6.0	P
D4EA;D4EA-F/-V;D4DA	CRDi	2.0L							
D3EA		1.5							
G4DF	CRDi	2.0/103kw							
D4FA	CRDi	1.5	22114-2A000		IN	31.5	11.05	6.01	F
D4FB;D4FB-L	16V	1.6							
D4FC		1.4	22115-2A000		EX	31.5	11.05	6.0	F-6
D3FA		1.1							
G4EC-G	16V	1.5i/75kw	22114-26901		IN	36.6	11.12	6.0	P
G4K	16V	1.5i/73kw	22115-26901		EX	41.0	11.12	6.0	P
G4FA	16V	1.4	22114-2B000		I/E	40.5	10.05	5.53	P
G4GC;G4GC-G	16V	2.0L	22114-23501		IN	46.0	11.05	6.01	P
G4GM-G;G4GB/-G	16V	1.8	22115-23501		EX	54.5	11.05	6.01	P-6
G4M Sonata		1.8i/70kw			Z	50.5	12.06	6.6	P
J3;J3 TCI;HJ3;OK53	CRDi	2.9/110kw	OK551-10-281		Z	52.7	12.05	7.01	F-6
XUD9;XUD9A/SD		1.9D/50kw	PEU		Z	52.0	14.06	8.01	A
XUD9;XUD9A/SD		1.9D/50kw	PEU		Z	48.0	14.05	8.01	F
D4CB	CRDi	2.5/103kw	22114-4A000		IN	43.3	12.06	7.02	P-3
			22115-4A000		EX	39.4	12.06	7.02	P-3



KIA

Engine Type	Cyl/V	C.C./CID	OEM NO	E&T NO	I/E	OL	OD	ID	TYPE
15BFD A5D Rio DOHC S6D G4EK ALPHA II	L4/16V 16V 16V L4/16V	1493cc 1.5 1594cc 1493cc	0K30E-10-281 HYUNDAI	EVGKI-01-Z	I/E	42.0	9.55	5.5	P
4AFE/7AFE KIA G4EK II	DOHC	1495	11122-15030 11122-74030	EVGTO-18-Z EVGKI-02-Z	I/E I/E	38.5	11.06	6.0	P
FE DOHC Sportage	16V	2.0	0FE3N-10-281 0FE3N-10-291	EVGKI-04-I EVGKI-04-E	IN EX	45.0 50.0	11.04 11.04	6.0 6.0	P P-6
BESTA 2.7	專用	MO18	0K711-34-580	EVGKI-05-Z	I/E	47.5	14.05	9.0	P
PREGIO J2	常用NO MO16		VN01-10-280 0K72A-32-880/90	EVGKI-06-Z	I/E	48.5	14.05	8.5	A
KIA 2.7/3.0	8V		0K65A-10-104	EVGKI-07-Z	I/E	49.0	14.05	8.5	A
RF;RF-CX;RF-N(~95) KIA R2 Besta Van		2.0D/TD 2.2D	RF01-10-280 MRF01-10-280 RF01-10-290 011-10-290	EVGMA-04-I EVGKI-08-I EVGMA-04-E EVGKI-08-E	IN IN EX	40.6 37.7	14.045 14.045	8.0 8.0	A-1 A-1-6
RF;RF-CX;RF-N(95~) KIA RF(~98)		2.0D/TD 2.0TD	RF01-10-280 MRF01-10-280 RFJ5-10-290 MRFJ5-10-290/291	EVGMA-04-I EVGKI-08-I EVGMA-09-E EVGKI-09-E	IN IN EX EX	40.6 46.5 46.5	14.045 14.045 14.045	8.0 8.0 8.0	A-1 A-1-6 A-1-6
RF(98~) DGMA-09-E		2.0TD	MRF01-10-104 MRFJ5-10-290/291	EVGKI-09-E	IN EX	41.0 46.5	14.03 14.045	8.03 8.0	P-1-3 A-1-6
FORD Vin 8 91~96 KIA 5BP;BPD MAZ B6;BP	16V L4/16V L4/16V	1.8L 1793/1839cc 1597/1839	B6Z1-10-280/180 F0CZ-6510A	EVGMA-14-I EVGKI-10-Z	I/E	45.0	11.05	6.0	P-1
B3;B3ME B5;B5E KIA B5;BFD;FE	8V/16V 16V L4/16V 16V 16V	1.3 1.5 1597cc 1839cc 1839cc 1.25	B6Z0/B620-10-280 B3Y0-10-280 E9JY-6510B B6Z0-10-290 B3Y0-10-290 E9JY-6510A	EVGMA-13-I EVGMA-13-E	IN IN EX EX	48.5 48.5	11.04 11.04	6.0 6.0	P-1 P-1-6
KIA B6;TC88 B6/Z/D/E/F B3 B1/B116	L4/8V L4/16V	1598cc 1598cc 1.6i 1.1	B6Y0-10-280 B6Y0-10-290 B6Y1-10-281	EVGMA-02-I EVGMA-02-E	I/E I/E I/E	50.0 50.0	12.04 12.04	7.0 7.0	A-1 A-1-6
D4BF;D4BH D4BB;D4BX;D4BA KIA D4BH Pregio(TB)		2.5 TD 2.5 D 2.5 D	22114-42000 22114-42900 22115-42000 22115-42900	EVGHI-02-I EVGHI-02-I EVGHI-02-E	IN IN EX EX	71.0 71.2 74.0 74.18	13.07 13.125 13.07 13.125	8.0 8.0 8.0 8.0	P P P-6 P-6
TB		1.8	22114-2Y100 22115-2Y100		IN EX	43.0 41.0	11.04 11.04	6.01 6.01	P P
TBD		1.8	0K24T-10-281 0K24T-10-291		IN EX	43.0 41.0	11.05 11.05	6.01 6.01	P-3 P



AUDI-VOLKSWAGE

Engine Type	Cyl/V	C.C./CID	OEM NO	E&T NO	I/E	OL	OD	ID	TYPE
1Y;1Z;AAZ;AEF;AQM;ANU	8V D	1896cc	056 103 419A	EVGAV-01-Z	I/E	36.5	12.08	8.0	G
AGP;AEY;AGD;ASX;WN;WH;AEF;1X;ALH;AHU									
AET;AEN;AAT;ABP	5/10V	2461cc							
APL;AEU;AEL;ACV;AXL;AVT;APA;ANJ;AVR									
AAF;ACU;1B;BBE;BBF			VW						
3A;AAD;AAE;AAC	4/8V	1984cc	AUDI						
ABK;ABT;ADW;CN;2E;ADY;AGG;AKR;NC;PS									
RT;SK;SL			SEAT						
AAH;AEJ;AFC	6/12V	2771cc	SKODA						
AEM	8/32V	4172cc							
AAR	5/10V	2309cc							
3D;AAS;DV;CP;DN	5/10V	2370cc							
1G;1S;ACT;ACL;AAB			CHR:5240925						
ABC;ACZ	6/12V	2598cc							
DS;JN;NE;JV;ABS;ADZ	4/8V	1781cc							
RP;1H;PG;2H;AAM;ANN;ADD;ADZ;NVP			VW						
ABS;ACC;DX;RF;RD;RM;RP;PV;SF			AUDI						
ABB;ABM;ADA;CR;CY	4/8V	1595cc							
DT;JK;AFT;EZ;ABN;1C;1V;AEK;AKS;CS			SEAT						
WV;YN;JP;ME;RA;SB;RE;RF;RL;PP;PN;XX			SKODA						
YM;YP;YS;YZ;1F;EG									
HY;KV;JT;KZ;MB;MC;RR	16V	2179cc							
FY;FZ;NV;MN;PY;ZA;ZF;AAV	8V	1272cc							
CK;ZC;ZB;YJ	8V	1471cc							
WT	8V	1716cc							
ABD;1W	8V	1391cc							
FJ	8V	1093cc							
AHV		1.0							
D24(T);D5244T;PB;D5252T		2.4	VOLVO	EVGVO-06-Z	I/E				
AAH;AEJ;AFC 95~	6/12V	2771cc	037 103 419B	EVGAV-02-Z	I/E	36.5	12.07	7.0	G
AGK;ATA;AUH;AXA TDI	4/8V	2798cc							
ABC;ACZ 95~	6/12V	2598cc	037 103 418B						
AXD;AXE	5/10V	2460cc							
BAC;ALK;ACV;AXL	5/10V	2461cc	1037143	EVGFO-09-Z					
AAB	5/10V D	2370cc							
AJS;AYH	V10/20V	4920cc	AUDI						
ADY;ATM;2E;AGG;AZL;BBX	4/8V	1984cc	VW						
AEG;APK;AKR;;ABF;AQY;ATU;AWG;AWF			SEAT						
AZL;AZH;AZJ;AZG;AZM			SKODA						
AFF;AFN;ALE;ALH;ALK;ABL	4/8V	1896cc	FORD						
AHF;AHH;AHU;AHL;AHB;AGR;AGP;AGD;AAZ									
ASV;ASZ;ASK;ASY;ASX;AXB;AXC;1X;1Y;1Z									
AEF;AEY;ATD;AUY;AXR;AVB;AVF;AQM;AKU;AWX									
ARL;AYQ;ANA;ARM									
BKC;BJB;BLS;BTB;BRV									
SEAT LEON 1.9 TDI									
ASZ	4/8V	1896 D							



AUDI-VOLKSWAGE

Engine Type	Cyl/V	C.C./CID	OEM NO	E&T NO	I/E	OL	OD	ID	TYPE
AHB;AKU;AKW	8V	1716cc	037 103 419B	EVGAV-02-Z	I/E	36.5	12.07	7.0	G
ADP;AFT;AKS;AKL;AEH;1C	8V	1595cc							
AWH;APF;AYZ;AUS;AUR;ANA;ARM;AZD;BCB									
AMY;BAY	3/6V	1422cc							
ANY;AYZ	3/6V	1191cc							
AGE;ACK;ALG;AMX	V6/30V	2771cc	058 103 415	EVGAV-03-Z	I/E	36.0	11.06	6.0	F
APR;AQO;ATQ	V6/30V	2771cc							
ADR;AEB;AFY	8V/20V	1781cc	AUDI						
AGN;AGU	8V/20V	1781cc	VW						
AJL;AJP;AJQ;AJH	8V/20V	1781cc	SEAT						
AMB;AMK;AMU;ANB	8V/20V	1781cc	SKODA						
APG;APU;APP;APY	8V/20V	1781cc							
APX;APT	8V/20V	1781cc							
AQA;AQE;AQX	8V/20V	1781cc							
ARK;ARZ;ARX;ARH	8V/20V	1781cc							
ARY;ARG	8V/20V	1781cc							
ATC	8V/20V	1781cc							
AUM;AUQ;AUL	8V/20V	1781cc							
AVJ;AVC;AVV;AYP	8V/20V	1781cc							
AWT;AWU;AWV;AWC	8V/20V	1781cc							
AWP;BAM;BEX;BFB	8V/20V	1781cc							
BGH;BGJ	V8/32V	4.2							
AQF;AUW;AUX	V8/32V	4.2							
ARS;ASG;AWN	V8/32V	4.2							
AGA;ALF;AML;AJG	6/30V	2393cc							
APS;ARJ;AMM;APZ	6/30V	2393cc							
ASN;BBJ	6/30V	2976cc							
AKC;AQG		3.7							
AGB	6/30V	2671							
AWA;AXW;BHD;BMB	16V/20V	1984cc							
BLR;BLX;BLY	16V/20V	1984cc							
BVY;BVZ	16V/20V	1984cc							
ARC;AVY;AUS;AZD	16V	1598cc							
BAD;BAG;BLF;BLP	16V	1598cc							
BCB;BGU	16V	1598cc							
AUA;AUD;AUB	16V	1390cc							
AFH;AFK;AKK;AKQ	16V	1390cc							
AMK;ANM;AHW;AXP	16V	1390cc							
AQQ;AVB;APE	16V	1390cc							
BBY;BCA;BBZ;BLN	16V	1390cc							
BKY;BKG;BKR	16V	1390cc							
AZQ;BME	L3/12V	1198cc							
BMD;AWY	L3/6V	1198cc							
AST;AVZ	16V	1.0							
Golf/Passat 特殊規格				EVGAV-04-Z	I/E	36.5	12.07	8.0	F
Golf/Passat 特殊規格				EVGAV-05-Z	I/E	42.5	12.07	8.0	F
Golf/Passat 特殊規格				EVGAV-06-Z	I/E	36.5	11.07	7.0	F



AUDI-VOLKSWAGE

Engine Type	Cyl/V	C.C./CID	OEM NO	E&T NO	I/E	OL	OD	ID	TYPE
AJM;ASZ;ATD;AVB;AVF;AWX ANU;AUY;ARL;AXC;AXB BTB;BUK;BPX;BVK	4/8V	1896cc	027 103 419	EVGAV-07-Z	I/E	38.1	12.06	7.0	G
				EVGAV-07-ZS	I/E	38.1	12.06	6.98	G
AMF	3/6V	1422cc	AUDI	特殊規格					
6A;9A	4/16V	1984cc	VW	EVGFO-10-Z					
NM	5/20V	1994cc	SEAT						
AAN	5/25V	2226cc	FORD						
3B	5/20V	2226cc	SKODA						
7A	5/20V	2309cc							
AGZ	5/10V	2324cc							
AXD;BLK/BAC;BLJ	5/10V	2460/2461							
AAA	6/12V	2792cc							
ABV	6/12V	2861cc							
PT	8/32V	3562cc							
AYH;AJS	10/20V	4921cc							
M104.900	6/12V	2792cc	000 012 00 14	EVGMB-18-Z					
PL	4/16V	1781cc	027 103 415	EVGAV-08-Z	I/E	38.0	12.05	7.0	F
KR	4/16V	1781cc							
113/F;113/AC/F		1.5/1.3	111 101 402A		IN	64.0	12.06	8.0	B
D		1.2	113 101 417A	EVGAV-09-E	EX	60.5	12.06	8.0	B-6
AJM;AXR;AVB;AUY;ATD T5 1900cc	4/8V	1.9TDi	AUDI VW	EVGAV-10-Z	I/E	31.5	12.05	7.01	F
JN, MG	SOHC 8V	1780cc	056 103 419A	EVGAV-01-Z	IN	36.5	12.08	8.0	G
JT, KZ/MC(T)	L5/SOHC 10V	2226cc	8942067620	EVGIS-08-I	EX	46.0	12.05	8.0	A-1
BSE;BSF;CCSA		1.6L		EVGAV-11-Z	I/E	38.6	12.05	6.0	F
GOLF/JETTA 2.0				EVGAV-12-Z	I/E	36.5	12.06	7.0	F
金龜車				EVGAV-13-Z		66.0	12.05	7.99	A-6
021A.1000		1.3L	SEAT	EVGSE-01-Z	I/E	42.0	13.52	7.0	P
021A.2000		1.5L	SE021012306A						
1000			SEAT	EVGSE-02-Z	I/E	45.0	13.07	7.0	P



BMW

Engine Type	Cyl/V	C.C./CID	OEM NO	E&T NO	I/E	OL	OD	ID	TYPE
M50B20 M;TU	6/24V	1991cc	11 12 1 715 373	EVGBM-01-Z	I/E	43.5	12.54	7.0	F
M70B50	12/24V	4988cc							
M40B18;ME	4/8V	1796cc							
M40B16;ME.8	4/8V	1596cc							
M50B25 M	6/24V	2494cc							
M43B18 C;Gas KAT	4/8V	1796cc							
M43B16	4/8V	1596cc							
M43B19 TU OL/UL	4/8V	1895cc							
M73B54	12/24V	5379cc							
S70B56	12/24V	5576cc							
M73B54	12/24V	5379cc	ROL						
M50B20 T;UM;TU	6/24V	1991cc	11 12 1 735 534	EVGBM-02-Z	I/E	43.5	12.55	6.0	F
M43B18 ;TU1	4/16V	1796cc							
M50B25 TU	6/24V	2494cc							
M52B25 TU	6/24V	2494cc							
M60B30	8/32V	2997cc							
M62B35 ;TU	8/32V	3498cc							
M52B28 GG;TU	6/24V	2793cc							
M54B30	6/24V	2979cc							
M44B19	4/16V	1895cc							
M60B40	8/32V	3982cc							
M62B44 ;TU	8/32V	4398cc		EVGRO-09-Z					
M20B20 V	6/12V	1991cc	11 12 1 280 523	EVGBM-03-Z	I/E	45.0	13.05	7.0	F
M20B20 L;LE;K;M1.Z7	6/12V	1991cc	11 12 1 267 676	EVGBM-031-Z	I/E		13.14		
M20B23 L;LE;K	6/12V	2316cc	11 12 1 267 677	EVGBM-032-Z	I/E		13.24		
M20B20 MO.E8	6/12V	1991cc							
M21D24 WW;WA	6/12V	2443cc							
M51D25 1/TU OL/UL	6/12V	2497cc							
M51 D25 TU;UL	6/12V	2497cc							
M20B27 MEE;ME.U	6/12V	2693cc							
M20B27 M1Z7	6/12V	2693cc							
M20B25 M.E;ME.8	6/12V	2494cc							
M20B25 M1Z7	6/12V	2494cc							
M40B18;S14B23	E30	2.3		EVGBM-04-Z	I/E	44.8	12.05	7.0	F-1
S38B35	E28/E24	3.5							
M10B16 N;V	4/8V	1573cc	11 12 1 263 642	EVGBM-05-Z	I/E	50.5	14.05	8.0	F
114/2;116	4/8V	1573cc							
M30B25 L;V	6/12V	2494cc							
M30B28 L;V	6/12V	2788cc							
M10B18 S;V	4/8V	1767cc							
118.3 KH	4/8V	1766cc							
M30B30 M.E7;V	6/12V	2986cc							
M30B32 LA;M;L;LU	6/12V	3210cc							
M30B34 MA;ME;M.45	6/12V	3430cc							
M30B35 ME;M.E7;L	6/12V	3430cc							
520 24V				EVGBM-06-Z	I/E	37.5	12.54	7.0	F-1
M51D25 OL;TU OL	6/12V	2497cc	11 12 2 244 464	EVGBM-07-Z	I/E	39.5	12.55	6.0	F
M51D25 UL;TU UL	6/12V	2497cc		EVGRO-07-Z					
M41 B17;D17	4/8V	1665cc		EVGOP-08-Z					
256T		2.5D	ROV						
25DT;X25DT;X25TD		2.5 TD	OPE						
735I V8	v8			EVGBM-08-Z	I/E	39.0	10.05	6.0	A



CATERPILLAR

Engine Type	Cyl/V	C.C./CID	OEM NO	E&T NO	I/E	OL	OD	ID	TYPE
3406;3406B 3408 3412	L6/24V V8/32V V12/48V	14.6L 18.0L 27.0L	4N2803	EVGCA-01-Z	I/E	82.8	17.5	9.51	A-8
D330C 1673 D333C;3306;1673C 112F;3304 920B;922B;930;944;950/1 955K/L;D4D LPG	L4/8V L6/12V L6/12V	7.0L 8.6L 10.5L	2P1262	EVGCA-02-Z	I/E	70.7	16.72	9.5	A-8
1676;D336 D334;1674 621;980	V8 L6/12V	10.5L 10.5L	5S2921 5S9291	EVGCA-03-Z	I/E	77.0	14.22	7.975	A
D343;D343D;1693 D346 D348 D349	L6/24V V8 V12 V16	14.6L 19.5L 29.2L 39.0L	6N2236 4N3665	EVGCA-04-Z	I/E	71.7	17.5	9.5	F-2-6-7
3508 3512 3516	V8 V12/48V V16/64V	34.5L 51.8L 69.0L	9Y1847	EVGCA-05-Z	I/E	102.9	17.5	9.5	A-8
S4S;CAT 3044 S6S;CAT 3046	L4 L6	3.3L 5.0L	32A01-01600 103-9247	EVGMI-21-Z EVGCA-06-Z	I/E	50.0	12.04	8.0	A-6
S6KT CAT 3066 CAT 3064 EX:USE S4E/S6E		6.4L 4.3L	34201-01600 ME202520 1838172 34601-10600 ME202523 1838173	EVGMI-22-I EVGCA-07-I EVGMI-22-E EVGCA-07-E	IN EX	45.0 56.0	13.035 13.035	8.0 8.0	P P-6
4.401/T4.401 1004.40/40T 1004.42/4.421 T6.601/6.601 1106-E60TA	L4/8V L4 L6/12V L6/12V	4.0L 4.2L 6.0L 6.6L	3313A012 (CAT)1850882 3318A705 (CAT)1639256	EVGPK-04-I EVGCA-08-I EVGPK-04-E EVGCA-08-E	IN EX	51.3 51.3	13.04 14.04	9.0 9.0	A-1 A-1



CHRYSLER

Engine Type	Cyl/V	C.C./CID	OEM NO	E&T NO	I/E	OL	OD	ID	TYPE
135 CID VIN 8,B,C,F,D	L4/8V	2.2L	5203789	EVGCH-01-I	IN	40.0	12.55	7.97	P
135 CID VIN A,C,E,P,R	16V	TURBO/2.2	4483714						
153CID VIN K	L4/8V	2507cc	4201391	EVGCH-01-E	EX	43.3	12.55	7.945	P
153 CID VIN J Turbo	L4/8V	2507cc	4483711						
201CID Vin 3,E,G,H,R,T,U	V6/12V	3.3L	4448072	EVGCH-02-Z	I/E	57.83	12.54	8.0	P
230CID Vin 1,L,P,EGH 91~4	V6/12V	3.8L	4882220						
197CID Vin J 98~01	V6/24V	3.2L			IN	51.8	11.54	6.98	3-SR
215CID Vin4,F,G,K,M,V 93~4	V6/24V	3.5L		EVGCH-03-E	EX	55.0	11.54	6.98	A
241CID Vin 6,X 07~11	V6/24V	4.0L							
3.3L 12V				EVGCH-04-I	IN	56.0	12.55	7.98	P
				EVGCH-04-E	EX	56.0	12.55	7.95	P-6
NEON 16V內銷				EVGCH-05-Z	I/E	48.0	11.04	5.955	A
				EVGCH-06-I	IN	38.8	11.065	6.0	P
				EVGCH-06-E	EX	43.0	11.065	6.0	P-6
GM VORTEC VIN 8	DOHC 16v	2.8L	ISU/GM	EVGGM-03-Z	I/E	44.0	11.07	5.97	A
ISU 2.9 VIN 9	DOHC 16v	2.9L	ISU/GM	EVGIS-28-Z					
GM VORTEC "6"	DOHC 16v	3.5L	ISU/GM	EVGCH-07-Z					
GM VORTEC VIN "E"	DOHC/L5	3.7L/20V	ISU/GM						
GM VORTEC VIN "S"	DOHC/L6	4.2L/24V	GM/SAB						
420A VIN "Y"	DOHC/16v	1997cc	(CHR)4667411						
N12B16A/W10B16A	INI COOPE	1.6L/16V	BMW						
NEON VIN "Y"	DOHC/16v	1996cc	CHR	140-8556+2					
ECLIPSE	16V	95~99	MIT						
ECC;EDV;EDZ		2.0/2.4	CHR						
JEEP POWER-TECH	DOHC/16v	2.4L	CHR						
VIN 9,B,J,X,EDZ	DOHC/16v	2.4L	CHR	140-8556+2					
VIN 8,E,S TURBO	DOHC/16v	2.4L	CHR	140-8556+2					



DETROIT DIESEL

Engine Type	Cyl/V	C.C./CID	OEM NO	E&T NO	I/E	OL	OD	ID	TYPE
53 Series 2V HEAD 2,3,4,6&8 Cylinder		1.7L	5131961	EVGDE-01-Z	I/E	60.0	12.7	6.37	F-7
53 Series 4V HEAD 2,3,4,6&8 Cylinder		3.5L			EX				
71 Series 2V HEAD 2,3,4,6,8,12&16 Cylinder		2.3L	5120930 5178590	EVGDE-02-Z	EX	82.5	14.33	8.74	A-7
71 Series 4V HEAD 2,3,4,6,8,12&16 Cylinder		4.7L	5129919	EVGDE-03-Z	EX	60.45	12.7	7.94	F-7
92 Series 4V HEAD 6,8,12&16 Cylinder		18.1L			EX				



FIAT

Engine Type	Cyl/V	C.C./CID	OEM NO	E&T NO	I/E	OL	OD	ID	TYPE
ALFA 8144.67.220	8V	2499cc D	4749395	EVGFI-01-Z	I/E	56.0	13.07	8.0	F
CIT 8140.43N.3585	8V	2798cc D	(OD:13.02)						
T9A(DJ5)		2.5 D	4749397						
8144.67;8144.97Y	8V	2499cc D	(OD:13.07)						
8140.27;8140.47/R;8140.67	8V	2499cc D	0220.97						
8140.43/N/S/C/B;8140.63	8V	2798cc D	(OD:13.06)						
8140.23	8V	2798cc D	ALFA/SEAT						
8140.07;8140.27;8140.47	8V	2499cc D	CIT/PEU						
8140.21	8V	2445cc D	OPE/REN						
F1AE0481C/FA/GA/HA/A		2.3 D	504053804	EVGFI-02-Z	I/E	49.0	10.08	6.01	A
F1AE0481D/N		3.0 D	CIT						
F1CE0481A/FA/HA/D		3.0 D	PEU						
8140.43S	8V	2798cc TD	REN						
127A/A1/A6/AB/AJ.000		1.0L	4373602(φ15.06)	EVGFI-03-Z	I/E	46.5	15.06	8.0	F
127A3.000;127A5.000		1.3 D	4373603(φ15.09)						
128A/AC5.000		1.1L	4373604(φ15.14)						
128A1/AS/AC.000;146A5.000/046		1.3L							
146B4.000;178A1.000;310A1.011		1.0L							
156A/A1.000		1.0L							
146B1.000;156A5.000		1.3 D							
A112A.000,A2*A5/B2.000		1.0L							
131C1.000		1.4L	4250801(φ14.05)	EVGFI-04-Z	I/E	42.0	14.05	8.0	F
131C2.000;132C.000;149C2.046		1.6L	4371508(φ14.10)						
154A.048;831B6.000;132AC.000		1.6L							
159A4.000/046;835C2/C4.000		1.8 ie							
835A2.000/046;836A5/A6.000		1.8 ie							
836C4.000;835C5.000		1.8 ie							
132D1.000;138AR1/AR2.000		2.0 L							
154A1/C5.000;132AZ2.000		2.0 L							
828B.000;831C2/A5.000		2.0i							
159A5/A6.046;834B.000/048		2.0 ie							
834B1/B2.000;835A5.000/046		2.0 ie							
146B2.000;149B2/B3.000	8V	1698cc D		EVGFI-05-Z	I/E	45.5	14.07	8.0	F
146B3.000		1.4 TD	4372160(φ14.1)						
149A7.000;831A1/A2/AB/B.000		1.3 L	4372161(φ14.15)						
160A1.000/048	8V	1372cc	4372162(φ14.25)						
146C5/D5.000		1.4 ie							
149C1.000;138A1/A2/A3.000	8V	1499cc							
128A.000;831B8.000	8V	1116cc							
831A1/B1.000		1.5 L							
146C6/D6.000;149C2.000		1.6 L							
831A4/A7/B3/B4/B7.000;831B7.046		1.6 L							
159B9.000;835A1.000/046;835C1.000		1.6 ie							
146A8.000/046		1.4 ie T		EVGFI-06-I	IN	45.5	14.05	8.0	F
176A4.000;176B6.000		1.4 GT	5997546	EVGFI-06-E	EX	45.5	14.01	8.0	F
Uno 83~;Punto 93~99			5997547(φ14.20)						



FIAT

Engine Type	Cyl/V	C.C./CID	OEM NO	E&T NO	I/E	OL	OD	ID	TYPE
ALFA AR67203	16V	2.0L	7616998	EVGFI-07-Z	I/E	52.0	14.04	7.0	F
160A5.000	16V	1756cc							
154E1.000;175A1/A4.000	16V	1995cc							
834B2/F1/F2.000	16V	1995cc							
836A2/A3/A4.000	16V	1995cc							



G.M.

Engine Type	Cyl/V	C.C./CID	OEM NO	E&T NO	I/E	OL	OD	ID	TYPE
189V,T,W,M	OHV/V6/12v	3137cc	ISU	EVGGM-01-Z	I/E	53.0	14.06	8.01	F
173S,W	OHV/V6/12v	2.8L	GMT/GMC		I/E				
207E,F	OHV/V6/12v	3.4L			I/E				
ISU 3.1 CPC		3.1L							
GMC122-1,B,P	OHV/8V	2.0L/122CID		EVGGM-02-I	IN	70.5	14.8	8.0	F
GMC134 90~93	OHV	2.2L/134CID		EVGGM-02-E	EX	59.5	14.8	8.0	F
GMT/GMC134	OHV	2.2L/134CID	24574524	EVGGM-06-I	IN	70.5	14.8	7.0	F
94~97			10198812	EVGGM-06-E	EX	59.5	14.8	7.0	F
		98-00			Z	58.14	12.98	7.02	1-P
GM VORTEC VIN 8	DOHC 16v	2.8L	ISU/GM	EVGGM-03-Z	I/E	44.0	11.07	5.97	A
ISU 2.9 VIN 9	DOHC 16v	2.9L	ISU/GM	EVGIS-28-Z					
GM VORTEC "6"	DOHC 16v	3.5L	ISU/GM	EVGCH-07-Z					
GM VORTEC VIN "E"	DOHC/L5	3.7L/20V	ISU/GM						
GM VORTEC VIN "S"	DOHC/L6	4.2L/24V	GM/SAB						
420A VIN "Y"	DOHC/16v	1997cc	(CHR)4667411						
N12B16A/W10B16A	MINI COOPER	1.6L/16V	BMW						
NEON VIN "Y"	DOHC/16v	1996cc	CHR	140-8556+2					
ECLIPSE	16V	95~99	MIT						
ECC;EDV;EDZ		2.0/2.4	CHR						
JEEP POWER-TECH	DOHC/16v	2.4L	CHR						
VIN 9,B,J,X,EDZ	DOHC/16v	2.4L	CHR	140-8556+2					
VIN 8,E,S TURBO	DOHC/16v	2.4L	CHR	140-8556+2					
F14D3/S3	16V	1.4	96103034	EVGDW-03-Z	I/E	40.0	11.06	6.0	A
A15MF/SMS	16V	1.5	96336671	EVGGM-04-Z					
A16DMS;F16D3;616L	16V	1588/1598	GMC						
L91 E-TEC II	16V	1.6L							
B10S/S1		1.0	11115A-70B00	EVGDW-02-Z	I/E	43.0	11.1	5.5	P
B12S1		1.2	94580080	EVGGM-05-Z					
F10NS CHEVROLET		1.6							
F8C/CV Matiz;Tico		0.8							
雪佛蘭 1.4/1.6			90108699	EVGGM-09-Z	I/E	45.6	11.05	7.0	P
PONTIAC 2300 16V				EVGGM-07-Z	I/E	44.0	13.04	7.0	A
GM 2.0				EVGGM-08-Z	I/E	41.0	11.05	7.0	P
301D	L4/8V	4.9L	CASE:6321A	EVGSC-01-I	IN	111.15	19.1	10.27	F
A401D;A401BD	L6/12V	6.6L							
451BD;BDT	L6/12V	7.4L	CASE:A11803	EVGSC-01-E	EX	81.7	19.1	10.27	F
G188D	L4/8V	3.1L	CASE:G2068	EVGSC-02-I	IN	82.6	16.69	8.72	F-2
207D	L4/8V	3.4L	CASE:G2069	EVGSC-02-E	EX	79.4	16.705	8.72	F
			CASE	EVGSC-03-Z	I/E	68.4	16.685	8.72	F



MAN

Engine Type	Cyl/V	C.C./CID	OEM NO	E&T NO	I/E	OL	OD	ID	TYPE
G2866;E2866;D2866	6/12V	11967cc	51032010087	EVGMN-01-Z	I/E	64.0	18.035	12.0	F
G2876;E2876;D2876	6/12V	12816cc	51032010088						
D2865	5/10V	9972cc	51032011034						
D2530	10/20V	15945cc	51032010093+0.2						
D2538	8/16V	12763cc	51032011035+0.2						
D2540	10/20V	17426cc	51032011037+0.4						
D2542	12/24V	20910cc							
D2556	6/12V	11045cc							
D2565	5/10V	9510cc							
D2566	6/12V	11407cc							
D2842;E2842	12/24V	21930cc							
D2840	10/20V	18273cc							
D2848	8/16V	14618cc							
D2555M	5/10V	9199cc							
D2865 LF06,20,22,23	5/10V	9972cc	51032010087	EVGMN-01-Z	IN	64.0	18.035	12.0	F
LUH02,05,07,08,09			51032010088						
D2866 LF03,05,06,09	6/12V	11967cc	51032011034						
LF10,15,21,LXF,LOH20			51032010102	EVGMN-02-E	EX	57.0	18.035	12.0	F
D2840 LF01,04,06	10/20V	18273cc							



MERCEDES BENZ

Engine Type	Cyl/V	C.C./CID	OEM NO	E&T NO	I/E	OL	OD	ID	TYPE
OM312			312 053 02 30	EVGMB-01-I	IN	78.0	15.05	9.0	A
OM321/322			312 053 05 30		EX	73.0	15.03	9.0	F
OM314.910/917/944	4/8V	3780cc D	312 053 02 30	EVGMB-01-I	IN	78.0	15.05	9.0	A
OM314.946/8;967	4/8V	3780cc D	352 053 12 29	EVGMB-06-I	IN	72.0	15.05	9.0	A-1
OM352.907/986	6/12V	5675cc D	312 053 05 30		EX	73.0	15.03	9.0	F
OM353.909	6/12V	5675cc D	352 053 16 30	EVGMB-02-E	EX	73.0	15.05	10.0	A
OM353.959	6/12V	5675cc D	352 053 20 30	EVGMB-01-E	EX	67.0	15.04	10.0	A
OM321;OM352.937			321 053 12 30	EVGMB-03-E	EX	78.0	15.04	10.0	A-6
OM327	6/12V	7980cc D	327 053 08 30	EVGMB-04-I	IN	85.0	16.035	10.0	A
OM360.966/967	6/12V	8725cc D	327 053 14 30	EVGMB-04-E	EX	77.0	16.035	10.0	A-6
OM346.911/918	6/12V	10809cc D	346 053 09 29	EVGMB-05-I	IN	67.5	15.05	9.0	A-1
OM355/H,A	6/12V	11581cc D	355 053 03 30	EVGMB-05-E	EX	86.5	15.05	9.0	A-1
OM353.950/1/2/3/4	6/12V	5675cc D	312 053 02 30	EVGMB-01-I	IN	78.0	15.05	9.0	A
OM353.970/1/5;958	6/12V	5675cc D	366 053 07 29	EVGMB-06-I	IN	72.0	15.05	9.0	A-1
OM353.959	6/12V	5675cc D	352 053 22 29						
			352 053 16 30	EVGMB-02-E	EX	73.0	15.05	10.0	A
			366 053 02 30		EX	67.0	15.03	10.0	A-1
OM356/357	6/12v	5958cc D	366 053 07 29	EVGMB-06-I	IN	72.0	15.05	9.0	A-1
OM362.906/909	6/12v	5675cc D	352 053 22 29	snap ring 5mm					
OM364.907/918/919	4/8v	3972cc D	366 053 02 30		EX	67.0	15.03	10.0	A-1
OM366.951	6/12v	5958cc D	352 053 37 30						
OM366.905/914,962,988		5958cc D							
OM360.911	6/12V	8725cc D	360 053 00 29		IN	79.0	16.04	10.0	F-1
			360 053 00 30		EX	71.0	16.04	10.0	F-1
OM401.906/912	6/12V	9572cc D	422 053 04 30	EVGMB-07-Z	I/E	67.0	18.03	12.0	F
OM401.973,5,8,9/989	6/12V	9572cc D	403 053 00 30						
OM401.994/984	6/12V	9572cc D	422 053 05 30				18.24		
OM402.906/910,1,2,6	8/16V	12760cc D	422 053 06 30				18.44		
OM402.924/926	8/16V	12760cc D							
OM403.916/932,1,5	10/20V	15960cc D							
OM403.918	10/20V	15960cc D	422 053 04 30	EVGMB-07-Z	I/E	67.0	18.03	12.0	F
OM404	12/24V	20911cc D	403 053 00 30						
OM407.905/908	6/12V	11040cc D	422 053 05 30				18.24		
OM407.951/955	6/12V	11412cc D	422 053 06 30				18.44		
OM421.905,6,8/951	6/12V	10965cc D							
OM422.905/907,9,11	8/16V	14618cc D							
OM422.913/954,7,8	8/16V	14618cc D							
OM422.906/10,12	8/16V	14618cc D							
OM422.953,4,5,6,9	8/16V	14618cc D							
OM422.908/914/917	8/16V	14618cc D							
OM422.919/921,20	8/16V	14618cc D							
OM422.963	8/16V	14618cc D							
OM423.905,6,7,8	10/20V	18273cc D							
OM423.950/951	10/20V	18273cc D							
OM424A/LA	12/24V	21930cc D							
OM427/H;447	6/12V	11970cc D							
OM440/446	8/16V	14618cc D							
OM441	6/12V	10965cc D							
OM442/440	8/16V	15080cc D							



MERCEDES BENZ

Engine Type	Cyl/V	C.C./CID	OEM NO	E&T NO	I/E	OL	OD	ID	TYPE
OM444A/LA	12/24V	21920cc D	422 053 04 30	EVGMB-07-Z	I/E	67.0	18.03	12.0	F
OM445	6/12V	10965cc D	422 053 05 30				18.24		
OM447,A/LA	6/12V	11970cc D	422 053 06 30				18.44		
M104.980/981	6/24V	2980cc	104 050 37 24	EVGMB-08-I	IN	35.5	13.55	8.0	F-1
M119.960	8/32V	4973cc							
M119.970/974	8/32V	4973cc	104 050 27 24	EVGMB-08-E	EX	38.0	13.55	9.0	F-1
M119.985	8/32V	4196cc							
M119.960	8/32V	4973cc	104 050 37 24	EVGMB-08-I	IN	35.5	13.55	8.0	F-1
M119.970/972/974	8/32V	4973cc	104 050 57 24	01-2520	EX	40.5	13.53	7.0	F-1
M119.985	8/32V	4196cc							
M104.990/991	6/24V	3199cc	104 050 52 24	EVGMB-09-I	IN	35.5	13.55	7.0	F-1
M119.960	8/32V	4973cc							
M119.970/2/4	8/32V	4973cc							
M119.985/971/975	8/32V	4196cc	104 050 47 24	EVGMB-09-E	EX	38.0	13.55	8.0	F-1
M120.980/1/3	12/48V	5987cc							
E60 AMG		W124	606 053 02 30	EVGMB-10-Z	I/E	37.5	12.56	7.0	F-1
500E AMG			111 053 11 29	EVGDW-04-Z					
M104.941/2/3/4/5	6/24V	2799cc	111 053 10 29						
M104.992/4/5/6	6/24V	3199cc	11 29(OD:12.70)						
M111.920/1	4/16V	1799cc							
M111.940/1/2/3/4/5/6/7/8		1998cc							
M111.955/6/7	4/16V	1998cc							
M111.960/1	4/16V	2199cc							
M111.970/3/5/4/7/8	4/16V	2295cc							
M111.981/2/3/4	4/16V	2295cc							
M112.943	6/18V	3199cc							
E20	SSA		SSA						
M104.992/5;M111.970	SSA								
M104.992/5;M111.970	DAE		DAE						
M161.973	DAE								
M166.940	4/8V	1397cc	606 053 02 30	EVGMB-10-Z	EX	37.5	12.56	7.0	F-1
M166.960/961	4/8V	1598cc	111 053 11 29						
M166.990/1	4/8V	1898cc							
M166.995	4/8V	2084cc							
M266.920	4/8V	1498cc							
M266.940	4/8V	1699cc	606 053 12 29		IN	37.5	12.56	6.0	F
M266.960/980	4/8V	2034cc							
OM604.915/7	4/16V	1997cc							
OM605.910/1/2	5/20V	2497cc							
OM605.960/2	5/20V	2497cc							
OM606.962	6/24V	2996cc							
M102.910	4/8V	1797cc	102 050 17 24	EVGMB-11-I	IN	46.0	14.035	8.0	F-1
M102.920/1/2/4	4/8V	1997cc	102 050 89 24		IN				
M102.939	4/8V	1997cc							
M102.961/2/3	4/8V	1997cc	102 050 18 24	EVGMB-11-E	EX	51.0	14.035	9.0	F-1
M102.979	4/8V	2299cc	102 050 05 62						
M102.980/1/2/7/5/9	4/8V	2299cc							
M102.996	4/8V	2299cc							
M102.945	4/8V	2299cc							



MERCEDES BENZ

Engine Type	Cyl/V	C.C./CID	OEM NO	E&T NO	I/E	OL	OD	ID	TYPE
M110.921/2/3	6/12V	2746cc	110 050 54 24	EVGMB-12-I	IN	51.5	14.035	9.0	F-1
M110.926/924	6/12V	2746cc	110 050 26 24						
M110.981/2/6	6/12V	2746cc	110 050 53 24		IN	51.5	14.04	9.0	F-1
M110.990	6/12V	2746cc	110 050 59 24	EVGMB-12-E	EX	54.0	15.05	9.0	F-1
M110.983/5/4/7/8/9	6/12V	2746cc	110 050 41 24						
M110.994	6/12V	2746cc	110 050 65 24		EX	54.0	15.04	11.0	F-1
M117.960/1/3	8/16V	4973cc	116 050 36 24		IN	47.5	14.04	9.0	F-1
M117.964/965	8/16V	4973cc	110 050 59 24 110 050 41 24	EVGMB-12-E	EX	54.0	15.05	9.0	F-1
M108.920	6/12V	2496cc	130 050 01 24	EVGMB-13-I	IN	55.0	14.04	9.0	F-1
M114.920/80	6/12V	2496cc							
M115.920/4	4/8V	2197cc							
M115.923/926	4/8V	1988cc							
M115.938/9	4/8V	1988cc							
M115.951/4/5	4/8V	2307cc							
M115.973/2	4/8V	2307cc							
M121.940	4/8V	1988cc	108 050 05 24	EVGMB-13-E	EX	45.0	15.04	11.0	F-1
M123.921	6/12V	2525cc							
M129.980/2	6/12V	2496cc							
M130.920/3/980/1/3/4	6/12V	2778cc							
M180.945/7	6/12V	2292cc							
M180.950/4	6/12V	2306cc							
M127.981	6/12V	2307cc	130 050 01 24 127 050 11 24	EVGMB-13-I	IN EX	55.0 50.0	14.04	9.0 10.0	F-1 F-1
M103.940/1/2/3	6/12V	2599cc	103 050 03 24	EVGMB-14-I	IN	42.0	14.035	8.0	F-1
M103.980/1/2/3	6/12V	2962cc	103 050 22 24		IN				
M103.984/5/7	6/12V	2962cc	103 050 07 24 103 050 27 24	EVGMB-14-E	EX	48.0	14.035	9.0	F-1
M116 (79~08)	8/16V	3818cc	116 050 47 24	EVGMB-16-I	IN	47.5	14.05	9.0	F-1
M116(85~91)	8/16V	4196cc							
M117(78~94)	8/16V	4973cc	116 050 53 24	EVGMB-16-E	EX	50.5	15.05	9.0	F-1
M117(85~)	8/16V	5547cc							
M116	8/16V	3499cc	116 050 47 24	EVGMB-16-I	IN	47.5	14.05	9.0	F-1
M117	8/16V	4520cc	116 050 41 24		EX	49.0	15.04	11.0	F-1
M112.916	6/18V	2597cc		EVGMB-15-Z	I/E	50.0	12.55	7.0	F
M112.910/1/5	6/18V	2398cc	113 053 03 29				12.75		
M112.920	6/18V	2799cc	113 053 04 29				13.16		
M112.940/1/2/4/5/6	6/18V	3199cc							
M112.947/949	6/18V	3199cc							
M112.951/3/960/1	6/18V	3199cc							
M112.970/2/3/5	6/18V	3724cc							
M113.940/1/2/3/4/8	8/24V	4266cc							
M113.960/1/2/3/4/5	8/24V	4966cc							
M113.966/7/8	8/24V	4966cc							
M113.980/1/2	8/24V	5439cc							
M113.985/6/7	8/24V	5439cc							
M113.990/1/2/3	8/24V	5439cc							
OM615	4/8V	2197cc D	616 053 03 29	EVGMB-17-I	IN	60.0	14.03	10.0	A-1
OM616	4/8V	2399cc D	611 053 15 29						
OM621	4/8V	1988cc D	616 053 03 20	EVGMB-17-E	EX	48.5	14.03	10.0	A-1
OM617	5/10V	2998cc D	621 053 36 30 616 053 03 30						
M104.900	6/12V	2792cc	000 012 00 14	EVGMB-18-Z	I/E	38.1	12.06	7.0	G



OPEL

Engine Type	Cyl/V	C.C./CID	OEM NO	E&T NO	I/E	OL	OD	ID	TYPE
15D15DT(T4EC1)	L4	1.5D/TD	8-94239-423-0	EVGOP-01-Z	I/E	43	11.55	7	P-1
17D;X17D(4EE1)	L4	1.7D	OPE		I/E				
17DT;X17DT(TC4EE1)	L4	1.7TDS	11122-15020	EVGTO-25-I	I/E				
10S	L4/8V	993cc	OPEL	EVGOP-02-Z	I/E	46.0	11.05	7.03	A-1
11N,11S/SR	L4/8V	1078cc		EVGDW-05-Z					
12N/NC/NV/NZ;12S/ST	L4/8V	1196cc							
12C;C12NZ;X12SE									
13N/NB;13S/SB;C13N	L4/8V	1297cc							
14NV;C14S/SE/SEL/NE	L4/8V	1389cc							
X14SE;X14NE/C/SZ									
16SV/NZR;E16NE/SE	L4/8V	1598cc							
C16NE/NZ2/LE;16LZ2									
C16SE/SEI;X16SE/SZR									
18E/SE/SEH;18SV/NV	L4/8V	1796cc							
C18NE/NZ/NV/NT									
E18NV/NVR									
20SE/SEH/NEJ/NE	L4/8V	1998cc							
C20NE/NEF/NEJ;X20SE									
1.3N/S;16SV			BEDFORD						
A18DMS;C18LE		1.8	DAEWOO						
A13DTC/DTE/DTR	L4/16V	1248cc							
X10XE;Z10XE/XEP	L4/16V	973cc	9158589	EVGOP-03-Z		39.0	10.03	5.0	F
X12XE;Z12XE/XEP	L4/16V	1229cc	90531109						
Z14XE/XEP	L4/16V	1364cc							
X16SEL	L4/16V	1598cc							
Z18XE/XEL	L4/16V	1796cc	SAAB						
Z20NET	16V	2.0T	9006082	EVGOP-04-Z	I/E	36.0	10.04	6.0	A
Z22SE	16V	2.2							
B207E;B207L/R	16V	1.8/2.0T	SAAB						
13N		1.3		EVGOP-05-Z	I/E	43.0	12.0	8.0	A-1
16N/NZ;16S/SH		1.6							
18E/SE;18N/S		1.8							
C18NE/NV/NT		1.8							
1.3NV/SC				EVGOP-06-Z	I/E	43.0	11.04	7.0	P
Astra;Kadett				EVGOP-07-Z	I/E	45.0	11.27	7.0	A-1
M51D25 OL;TU OL	6/12V	2497cc	11 12 2 244 464	EVGBM-07-Z	I/E	39.5	12.55	6.0	F
25DT;X25DT;X25TD		2.5 TD	OPE	EVGOP-08-Z					



PERKINS

Engine Type	Cyl/V	MODEL	OEM NO	E&T NO	I/E	OL	OD	ID	TYPE
3.152		2.5D	33261723	EVGPK-01-Z	I/E	62.0	12.74	8.0	A-6
AD4.203		3.3D	732445M1						
4.203									
6.305		5.0D	6361520						
4.99		1.6D	404E6510A	EVGFO-08-Z	I/E				
3.152(-70)		2.5D	0420002	EVGPK-02-Z	I/E	66.0	12.73	7.95	C-6
6.305(-62)		5.0D							
P3/3.144		2.4D							
P4/4.192		3.1D							
P6/6.288		4.7D							
4.236/A4.236	L4/8V	3864cc	33261732	EVGPK-03-I	IN	58.0	15.92	9.51	F
4.248	L4/8V	4064cc	795713R1						
6.372/6.372.4	6/12V	6100cc	736297M91						
6.354/.2	6/12V	5794cc	3343F041						
4.212/A4.212			2236556						
	L4/8V	3475cc	33261752	EVGPK-03-E	EX	61.1	15.92	9.505	F-6
T6.354/.1/.2/.3/.4	6/12V	5794cc	3343J002/021						
T4.40/T6.60		6.0TD	2236557						
			748420M1						
			796122R1						
			736296M91						
			33261754		EX	61.1	15.92	9.52	F
1104C-44(T)/E44(T)	L4/8V	4.4L	3313A012	EVGPK-04-I	I/E	51.3	13.04	9.0	A-1
1103A-33;1103-33T	L3	3.3L	(CAT)1850882						
1103A/B/C									
3054TNA;3054B	L4	4.0/4.2L							
3054C & E	L4	4.4L							
4.401/T4.401	L4/8V	4.0L	3313A012	EVGPK-04-I	IN	51.3	13.04	9.0	A-1
1004.40/40T			(CAT)1850882						
1004.42/4.421	L4	4.2L	3318A705	EVGPK-04-E	EX	51.3	14.04	9.0	A-1
T6.601/6.601	L6/12V	6.0L	(CAT)1639256						
1106-E60TA	L6/12V	6.6L							
4154;4.154		2.5D	3313E001/735	EVGPK-05-Z	I/E	54.0	12.75	8.0	A
4.165		2.7D	33261742						
G3.152	L3	2.5L	6397649						
VW CG2.7D									
4108		1.8D	3313E001/735	EVGPK-05-Z	IN	54.0	12.75	8.0	A
4.108			33261742						
4.107		1.8	6397649						
4.99		1.6D	33261723	EVGPK-01-Z	EX	62.0	12.74	8.0	A-6
			732445M1						



PEUGEOT

Engine Type	Cyl/V	C.C./CID	OEM NO	E&T NO	I/E	OL	OD	ID	TYPE
159 XU9C/2S	4/8V	1905cc	0220.64	EVGPE-01-I	IN	38.5	13.07	8.0	F-3
180A/Z XU5J-J/JA/JP	4/8V	1581cc							
B1A XU51C&_K	4/8V	1581cc							
B1A/BAZ XU51CP	4/8V	1581cc							
B1E XU51C	4/8V	1581cc							
B2A XU52C/S;_K	4/8V	1581cc							
B6B/180Z XU5J	4/8V	1581cc							
B6D XU5J	4/8V	1581cc							
BAZ XU5CP	4/8V	1581cc							
BDY XU5M2Z/3Z	4/8V	1581cc	0220.72	EVGPE-01-E	EX	45.0	13.07	8.0	F
BDY XU5JP	4/8V	1581cc							
BDZ XU5M	4/8V	1581cc							
BFZ XU5JP	4/8V	1581cc							
D2A XU92C/2S	4/8V	1905cc							
D2B XU9S	4/8V	1905cc							
D2C/D6B XU92C/S	4/8V	1905cc							
D6B XU9JA/Z	4/8V	1905cc							
DDZ XU9M	4/8V	1905cc							
DFZ XU9J1	4/8V	1905cc							
DKZ XU9JA/Z/2C/S	4/8V	1905cc							
L6A XU7P/K	4/8V	1762cc							
LFW XU7JP/B	4/8V	1762cc							
LFZ/LFW XU7JP	4/8V	1762cc							
RFL XU10J2U	4/8V	2.0							
159A	4/8V	1.9							
171A/B/D	4/8V	1.6							
UFZ (ZPJ)	V6/12V	3.0			IN	48.4	13.07	8.01	P
Z7W700/2/6/7/9(REN)	V6	2.8	0227.71(13.28)				13.28		
Z7W712/3/7/9(REN)	V6	2.8							
Z7X721/2/3/6(REN)	V6	3.0	0220.72	EVGPE-01-E	EX	45.0	13.07	8.0	F
B25ET(VOL)		2.4T	0220.17(13.28)				13.28		
B280E/B280F(VOL)		2.8/2.9							
D6C XU9J4	16V	1.9GTi	0220.73	EVGPE-02-I	IN	40.0	12.07	7.0	F-3
DFW XU9J4Z	16V	1.9/MI-16							
RFT XU10J4	16V	2.0							
RFY XU10J4Z	MI-16	2.0	0221.19	EVGPE-02-E	EX	40.0	12.07	7.0	F
RGZ XU10J4TE-Z	16V	2.0T							
150C		1.4E							
LEY XU7JP	16V	1.8	0221.19	EVGPE-02-E	I/E	40.0	12.07	7.0	F
RFV XU10J4R	16V	2.0/605/806							
180C XU8	4/8V	954cc	0220.59	EVGPE-03-Z	I/E	47.5	13.06	7.0	F
CDY/Z TU9M		954cc							
H1B TU1	4/8V	1124cc							
HDY TU1M		1124cc							
HDZ TUIM/MZ		1124cc							
K1D TU3A/AN/S/M/2/2K/MC		1361cc							
K2B TU3A/AN/S/M/2/2K/MC		1361cc							
K2B TU3S	4/8V	1361cc							
KAY TU3FCP	4/8V	1361cc							
KDY TU3A/AN/S/M/2/2K		1361cc							



PEUGEOT

Engine Type	Cyl/V	C.C./CID	OEM NO	E&T NO	I/E	OL	OD	ID	TYPE							
KDZ TU3A/AN/S/M/2/2K/MC/F2		1361cc	0220.59	EVGPE-03-Z	I/E	47.5	13.06	7.0	F							
KFV/KFW/X TU3JP		1361cc														
KDX TU3MC		1361cc														
TU3FCP		1.4														
HFX TU1JP		1.1														
150F		1.4E														
C1A/H1A/H1B/HAZ TUC1P		1.1														
K1F/K1H TU3A		1.4														
K2A/B/D		1.4														
KFZ/KFY TU3FJ2		1.4GTi														
XV8 TU9	4/8V	954cc														
R5A XU102C		2.0/605								0220.85	EVGPE-04-I	IN	43.5	13.06	8.0	F
RFU XU10J2		2.0/806	0221.21	EVGPE-04-E	EX	50.5	13.06	8.0	F							
RFX XU10J2/2C	4/8V	1998cc														
RFZ XU10J2Z		2.0														
RGX/Y XU10J2TE		2.0T														
105 XM7/A/P	1.8	505/J7	0220.25	EVGPE-05-Z	I/E	55.0	14.05	8.0	F							
106 XN1	2.0	505	0220.25	EVGPE-05-Z	I/E	55.0	14.05	8.0	F							
XN1/A/P/T	2.0	404/504/505														
106E XN1A	2.0	504														
107 XN2	2.0 Ti	504														
KF5/KF6	1.8i	504														
XB5	1.5	404														
XC5/6/P/KF1/2	1.6GT	J7/J9														
XC7/P	1.6	505/504														
XM1/XM7	1.8	504														
170A/B/D/C	2.0	J5/C25														
XD88	8V	1948cc D								0220.16	EVGPE-06-Z	I/E	54.5	14.07	8.5	A
XD4x88/XD4x90	8V	504								0220.16	EVGPE-06-Z	I/E	54.5	14.07	8.5	A
147/134 XD2/XD2S	8V	2304cc D														
XD2PX94	8V	2304cc D														
XD3P	8V	2498cc D														
XDP88	8V	1948cc D														
XDPx90	8V	2112cc D														
152A/B XD3T/E	8V	2498cc D														
155 XD3	8V	2498cc D														
SFA/B	8V	2498cc D														
STR/STP	8V	2498cc D														
WTA	8V	2112cc D														
XD4.88	8V	1948cc D														
YTR/T	8V	2304cc D														
RFS XU10J4RS	Gti/16V	2.0/306	0221.25	EVGPE-07-Z	I/E	40.8	12.08	6.0	F							
1KRFE 107		1.0	0221.28	EVGPE-09-Z	I/E	34.5	9.74	5.01	P							
1KR-FE C1(PM,PN)		1.0	0220.40	EVGTO-41-Z	I/E	51.2	14.05	8.0	F							
117 XR5A,S		1.5														
118 XL5,S;XK5		1.3														
142 XR5A,S		1.5														
XK5		1.1														



PEUGEOT

Engine Type	Cyl/V	C.C./CID	OEM NO	E&T NO	I/E	OL	OD	ID	TYPE
109 XW3/7	1.1	104	0220.51	EVGPE-08-Z	I/E	47.3	13.055	8.0	F
109F/N XW7	1.1	205							
121 XW3S	1.1	104							
129 XZ5	1.2	104							
150 XY6B	1.4	205							
150B/H XY8	1.4	205							
150D/G XY7	1.4	205							
126/150700/X5J7	1.4		79 02 102 332						
129D XZ7R	1.2								
108C	0.95								
109_5;109_5E/F/K	1.1								
109K/129.5	1.1								
150C/F	1.4								
A-XY6C	1.1								
K3A	1.4E								
405 1.8/2.0噴射				EVGPE-11-I	IN	43.0	14.06	8.0	F
				EVGPE-11-E	EX	50.5	14.06	8.0	F



RENAULT

Engine Type	Cyl/V	C.C./CID	OEM NO	E&T NO	I/E	OL	OD	ID	TYPE
688,689,C1C 688711,712,713 C1E714,718,719,726,715,720 C1E700,750,752,754,756,760 C1C708 800705,71302,B1B707 689710 C1G700/2,710,720/2,730 81002,8100297,81006 810719,726,729,725 847725,C2J713,720,730 C1J715,760,764,770,782/4/8,792/6 C2J700,780/1/8,798,766/7/8 C2J710,718,717,720 C2J755/6/7,772,782,784 B11;B130 B14,3E/4S	8V	0.9L 1.1L 1.1L 1.1L 1.1L 0.8L 0.95L 1.2L 1.3L 1.3L 1.4L 1.4L 1.4L 1.4L 1.4L 1.4L	07 10 939 000 00 03 102 891 VOL 3102891-3	EVGRE-01-Z	I/E	41.5	11.16	7.0	A-1-2
C3J700,702,710,760,762 E5F;E7F700/6/8,706,730,750 E6J700,701;E7J624,626,764 E7J700,710/1/8/9,754/6/7 E7J634,635,780,742,764,770/1 K7J700/1,710,714 K7M702/3,720,744/5,790 G8T706,790,714,716,740,760 G8T752,794 EJ7A	L4/8V L4/8V L4/8V L4/8V	1.4 1171cc 1390cc 1390cc 1598cc 2.2L 1.4L	 DACIA	EVGRE-02-I EVGRE-02-E	IN EX	42.0 49.0	12.05 12.05	7.0 7.0	F-1 F-1
852710,720,750 J8S600,610,612,620;J8S330 J8S702/4/6/8;711,712,714 J8S772,776,778,740,758 J8S784,786,788		2.1D 2.1D 2.1D 2.1D 2.1D		EVGRE-03-Z	I/E	49.0	13.06	8.01	F
J8S708,800,814,890 F8M700,720,730,736,760 F8Q620,624,722,724,774,776 F8Q710,730/2,740/4,756,764 F8Q788,790;F9Q744 D16 D4192;D19T F8QT	L4/8V L4/8V L4/8V L4/8V	2068cc D 1596cc D 1.9 D 1.9 D 1.9 D 1596cc D 1870cc D 1.9 TD	 VOL MIT	EVGRE-04-Z	I/E	39.0	13.08	8.0	F
DACIA K4M690,694,752 D4F712,730 F4R720,722 K4M752,710 F4R720 D4F702/4,712/4/6,740,764 D4F772,784;D4D700,720 F4P720/2,760,770/1/3/4/5 K4J700,712/3/4,730/2,750	L4/16V L4/16V L4/16V L4/16V L4/16V L4/16V L4/16V L4/16V	1598cc 1149cc 1998cc 1598cc 1998cc 1149cc 1149cc 1783cc 1390cc	77 00 109 151 NIS OPE REN	EVGRE-05-Z EVGNI-40-Z	I/E	40.5 40.8	11.065 11.09	5.5 5.5	A A



RENAULT

Engine Type	Cyl/V	C.C./CID	OEM NO	E&T NO	I/E	OL	OD	ID	TYPE
K4J770,780	L4/16V	1390cc	77 00 109 151	EVGRE-05-Z	I/E	40.5	11.065	5.5	A
K4M700/1/4/8/9,740/8,710/1/	L4/16V	1598cc	NIS	EVGNI-40-Z		40.8	11.09	5.5	A
K4M720/4,750/2/3,760/1/4/6	L4/16V	1598cc							
K4M782,790,800,801/4	L4/16V	1598cc							
F4R700/1,712/3/4/5,730/6/8	L4/16V	1998cc							
F4R740/1/6/4,760/1/2/4/6	L4/16V	1998cc							
F4R770/1/4/6,780/4/7	L4/16V	1998cc							
F4R791/4/5/7/6,811,830	L4/16V	1998cc							
R9				EVGRE-06-I	IN	37.35	11.16	7.0	A-1-2
				EVGRE-06-E	EX	41.4	11.16	7.0	A-1-2
R18D				EVGRE-07-Z	I/E	49.0	14.08	8.0	F
R11,R21 短				EVGRE-08-Z	I/E	39.2	13.06	8.0	F
R11,R21 長				EVGRE-09-Z	I/E	48.0	13.06	8.0	F
UFZ (ZPJ)	V6/12V	3.0			IN	48.4	13.07	8.01	P
Z7W700/2/6/7/9(REN)	V6	2.8	0227.71(13.28)				13.28		
Z7W712/3/7/9(REN)	V6	2.8							
Z7X721/2/3/6(REN)	V6	3.0	0220.72	EVGPE-01-E	EX	45.0	13.07	8.0	F
B25ET(VOL)		2.4T	0220.17(13.28)				13.28		
B280E/B280F(VOL)		2.8/2.9							
109 XW3/7	1.1	104	0220.51	EVGPE-08-Z	I/E	47.3	13.055	8.0	F
109F/N XW7	1.1	205							
121 XW3S	1.1	104							
129 XZ5	1.2	104							
150 XY6B	1.4	205							
150B/H XY8	1.4	205							
150D/G XY7	1.4	205							
126/150700/X5J7	1.4		79 02 102 332						
129D XZ7R	1.2								
108C	0.95								
109_5;109_5E/F/K	1.1								
109K/129.5	1.1								
150C/F	1.4								
A-XY6C	1.1								
K3A	1.4E								



ROVER

Engine Type	Cyl/V	C.C./CID	OEM NO	E&T NO	I/E	OL	OD	ID	TYPE
CB90	3/6V	993cc	550621301	EVGRO-01-Z	I/E	50	12.08	7	A-1
CB22;CB Mini Mk I		1.0/0.9	550621301	EVGDA-02/05-Z					
D16A8 216/416		89~99	12204-PJ7-305	EVGHO-03-I	IN	47.5	11.065	5.5	6-內銷
D16A9 216/416		89~99	FDU1256(ROV)	EVGRO-02-I	IN		11.075		6-外銷
D16Z2 216 Gsi		89~99	12205-PJ7-305	EVGHO-03/5-E		54.0	11.065	5.5	6-內銷
F18A3 618		93~99	FDU1260(ROV)	EVGRO-02-E	EX		11.075		6-外銷
F20Z1/Z2 620		93~99			EX				
EV1/EV2	L4/8V	1487/91	12204-PA6-300/5	EVGHO-08-I	IN	49.9	12.09	6.6	P
EW2/3/4		85~89	DBP9272	EVGRO-03-I					
EV2 216(ROVER)			DBP9273	EVGHO-13-E	EX	55.0	12.075	6.6	P
				EVGRO-03-E			12.105		外銷
12A2A/A2D/A2E,L		1.3	12G1111	EVGRO-04-Z	I/E	43.0	11.94	7.12	A-1
99H,99H997P/A53P		1.0L							
99HC20P/A65P;A1.0		1.0L							
Metro Van;Mini Mk I		1.0L							
BMC Serie A		0.8L							
12H;12HC32;12H999AA		1.3L	12G1963	EVGRO-05-Z	I/E	42.86	11.96	7.14	P-1
12H996AA;12HA83AA			12G062302						
12HE/HL;12V									
A1.3;A1275									
20HS 820e,SE,Si			UAM2514	EVGRO-06-I	IN	48.5	12.06	7.12	A-1-3
			UAM2515	EVGRO-06-E	EX	53.0	12.05	7.12	A-1-3
M51D25 OL;TU OL	6/12V	2497cc	11 12 2 244 464	EBGBM-07-Z	I/E	39.5	12.55	6.0	F
M51D25 UL;TU UL	6/12V	2497cc							
M41 B17;D17	4/8V	1665cc							
256T		2.5D	ROV	EVGRO-07-Z					
25DT;X25DT;X25TD		2.5 TD	OPE	EVGOP-08-Z					
14K4C/D;14K2/K2A	L4/16V	1396cc	WAM1452	EVGRO-08-Z	I/E	30.0	9.85	6.0	A
14K4F	L4/16V	1396cc							
K16-1.6	L4/16V	1588cc							
18K4F/K4K	L4/16V	1796cc							
448S2		4.4L	11 12 1 735 534	EVGBM-02-Z	I/E	43.5	12.55	6.0	F
M62B44 ;TU	8/32V	4398cc		EVGRO-09-Z					



SCANIA

Engine Type	Cyl/V	C.C./CID	OEM NO	E&T NO	I/E	OL	OD	ID	TYPE
DC9.01/03/04/11/12/13/16/18			1403823	EVGSC-01-Z	I/E	73.0	16.02	10.0	F-8
DC11.01/02/03/04/06/08/09	6/24V	10640cc							
DC11.07	6/12V	10640cc							
DC11-340/380	6/24V	10640cc							
DC12.01/02/03/05/06/08/09/14	6/24V	11716cc							
DC12 55A294/316/331	6/24V	11716cc							
DC12 58A257/58A272	6/24V	11716cc							
DC12.10/11/12/13/15	6/24V	11716cc							
DC12 50A272/50A316/50A330	6/24V	11716cc							
DC12-420	6/24V	11716cc							
DC16.01/02/03/04/05/06/08	8/32V	15600cc							
DC16 40A404/40A432	8/32V	15600cc							
DC16 41A294/41A331	8/32V	15600cc							
DC16 47A353/47A382	8/32V	15600cc							
DT12.02/06/08									
DT12.11/12									
DSC11.03/06/08/13/16/17	6/12V	11022cc	1521210	EVGSC-02-I	IN	75.0	18.01	11.0	F-8
DSC11.21/22/23/30/70/79/81	6/12V	11022cc	393263						
DSC14.03/08/09	8/16V	14181cc	1521209	EVGSC-02-E	EX	68.2	18.01	11.0	F-8
DSC14.10/13/15/16	8/16V	14181cc	393264						
			1398624						
DN9.01;DS9.01/02/03/06/08	6/12V	8476cc	300957	EVGSC-03-I	IN	80.0	18.01	11.0	A-8
DS9.B01/B02/05/05B01/05B02	6/12V	8476cc	1523410	EVGSC-03-I2		80.0	18.03	10.985	A-7
DSC9.01/02/07/08/09	6/12V	8476cc		內銷用					
DSC9.10/11/12/13/15	6/12V	8476cc							
D10;DS10	6/12V	10260cc							
D11;DC11.03;DSC11 Gas	6/12V	11022cc							
DS11.15/34/73/75	6/12V	11022cc							
DSC11.03/04/06/08/10/13	6/12V	11022cc							
DSC11.16/17/18/21/22/23/24	6/12V	11022cc							
DSC11.27/30/35/36/39	6/12V	11022cc	300958	EVGSC-03-E	EX	73.0	18.01	11.0	A-8
DSC11.70/71/74/75/79/81	6/12V	11022cc		EVGSC-03-E2		73.0	18.03	10.985	A-7
DSC14.06/08/09/10/13/15/61	8/16V	14181cc		內銷用					
DS14;DN14		14.2D							
DSI14.47/50/60/61/63	8/16V	14181cc							
D420;D440		5.6D;6.2D							
D610/620		8.4D							



VOLVO

Engine Type	Cyl/V	C.C./CID	OEM NO	E&T NO	I/E	OL	OD	ID	TYPE
D100	6/12V	9600cc D	422320	EVGVO-01-I	IN	82.0	18.0	11.0	A
TD100/101/102/103	6/12V	9600cc D	1545199						
TAD1030/1032	6/12V	9600cc D							
THD100/101/102	6/12V	9600cc D							
MD100;TMD100/102	6/12V	9600cc D							
TAMD102/103	6/12V	9600cc D							
D120	6/12V	12000cc D	421297	EVGVO-01-E	EX	66.0	18.0	11.0	A
TD120/121/122/123	6/12V	12000cc D	1545135-4						
TAD120/121	6/12V	12000cc D	11129092						
TAMD120/121/122	6/12V	12000cc D							
TID120/121	6/12V	12000cc D							
TMD120/121/122	6/12V	12000cc D							
THD102 KB/KD	6/12V	9600cc D	424868/422762		IN	71.8	17.99	11.04	A
TAMD102 A/D	6/12V	9600cc D	421297	EVGVO-01-E	EX	66.0	18.0	11.0	A
D70	6/12V	6730cc	421297	EVGVO-01-E	I/E	66.0	18.0	11.0	A
TD70A/B/C	6/12V	6730cc							
TD70A/B/C	6/12V	6730cc							
D60A (F609)	6/12V	5480cc TD	465157-6	EVGVO-02-Z	I/E	64.5	16.0	8.0	F
TD60 (F611)	6/12V	5480cc TD							
TD60 (F610,3,4,6)	6/12V	5480cc TD							
TD61F (FL614)	6/12V	5480cc TD							
TD63	L6	5.5L	477877		I/E	64.5	15.99	8.0	8-P
TD71	L6	6.7L	477792						
B234F	4/16V	2316cc	1378960	EVGVO-03-Z	I/E	55.0	12.05	7.0	F
B204E	4/8V	1986cc							
B204FT	4/8V	1986cc							
B230A/E		2.3	419652	EVGVO-04-I	IN	52.0	13.52	8.0	F
B230ET		2.3T							
B230FB	16V	2.3							
B230FT		2.3T	463771	EVGVO-04-E	EX	52.0	13.52	8.0	A
B23A/E		2.3	35476035						
B23ET		2.3T							
B200E/F/K		2.0							
B21A/E		2.1	463771	EVGVO-04-E	I/E	52.0	13.52	8.0	A
B21ET		2.1T	35476035						
B19A		2.0	3547603						
B30A	6/12V	2978cc	419652	EVGVO-04-I	IN	52.0	13.52	8.0	F
B230F	4/8V	2316cc	419653		EX	59.2	13.5	8.0	F
L3;L3C1;GZ	16V	2.3	LFY1-10-281	EVGMA-19-Z	I/E	39.0	11.05	5.5	A
L8;L813	16V	1.8	ZJY1-10-281		I/E				
CSDA/B;QQDA/B	16V	1.8							
B4184S11		1.8	VOL	EVGVO-05-Z					
D24(T);D5244T		2.4	VOLVO	EVGAV-01-Z	I/E	36.5	12.08	8.0	G
PB;D5252T		1.8/2.5	VOLVO	EVGVO-06-Z					
UFZ (ZPJ)	V6/12V	3.0			IN	48.4	13.07	8.01	P
Z7W700/2/6/7/9(REN)	V6	2.8	0227.71(13.28)				13.28		
Z7W712/3/7/9(REN)	V6	2.8							
Z7X721/2/3/6(REN)	V6	3.0	0220.72	EVGPE-01-E	EX	45.0	13.07	8.0	F
B25ET(VOL)		2.4T	0220.17(13.28)				13.28		
B280E/B280F(VOL)		2.8/2.9							



VOLVO

Engine Type	Cyl/V	C.C./CID	OEM NO	E&T NO	I/E	OL	OD	ID	TYPE
D12A 340/380/420 FH12;FL12;B 12	6/24V	12130cc	1546437 20905400	EVGVO-07-Z	I/E	83.4	14.99	8.0	F
D12C 340/380/420/460 FH12;FM12	6/24V	12130cc							
D12D 340/380/420/460/500 FH12;FM12									
D9A 260/300/340/380	FM 9								